

OWNER'S MANUAL



PBR

Premium Belted Roll Tarp

End Dumps, Belly Dumps,
Dump Bodies, Farm Boxes,
Grain Trailers, & Open Top Vans



READ BEFORE INSTALLING

P.O. Box 713, 2309 Shur-Lok Street, Yankton SD 57078

Phone: USA 1-800-4 SHUR-LOK (1-800-474-8756)

Fax (605) 665-0501

Web Site : <http://www.shurco.com>



WARRANTY

Shur-Co. warrants that all new, unused products are free from defects in material and workmanship. This Warranty is effective if the product is properly installed and used for the purpose intended and applies to the original buyer only. Shur-Co.'s obligation under this warranty is limited to repairing or at it's option, replacing any part that is returned, transportation prepaid, to Shur-Co., Yankton, South Dakota, if the product is, in our judgment, in fact, defective. All materials returned without written authorization will be refused. Shur-Co. shall not be liable or responsible to supply or pay labor to replace any part found defective, nor shall it be liable for any damages of any kind or nature to person, product, or property.

There are no warranties for used products or products that have been repaired, altered, modified, subjected to misuse, negligence, accident or ordinary wear and tear.

Shur-Co. products are sold without any express warranty except as set forth above.

No person is authorized to modify the foregoing Warranty in any respect whatsoever.

Shur-Co. is not obligated to honor warranty claims if approved O.E.M. or genuine Shur-Co. parts are not utilized.

Shur-Co.

PO Box 713
2309 Shur-Lok Street
Yankton, SD 57078
Ph: 1-800-4 SHUR-LOK(1-800-474-8756)
1-605-665-6000
Fax: 1-605-665-0501

Service Centers

Shur-Co. of North Dakota
920 38th St. NW, exit 66
Fargo, ND 58102
Ph: 1-701-277-5714
Fax: 1-701-877-1283

Shur-Co. of Ohio
1100 N. Freedom
P.O. Box 827
Ravenna, OH 44266
Ph : 1-330-297-0888
Fax: 1-330-297-5599

Shur-Co. of Houston
34505 I-10 West
South Frontage Rd.
Brookshire, TX 77423
Ph: 1-281-934-1007
Fax: 1-281-934-3311

Shur-Co. of Oklahoma
1604 E. US Hwy 66
El Reno, OK 73036
Ph: 1-405-262-7600
Fax: 1-405-262-3842

Shur-Co. of Colorado
10220 Brighton Rd
Henderson, CO 80640
Ph: 1-303-289-2050
Fax: 1-303-289-2298

Open Top Van

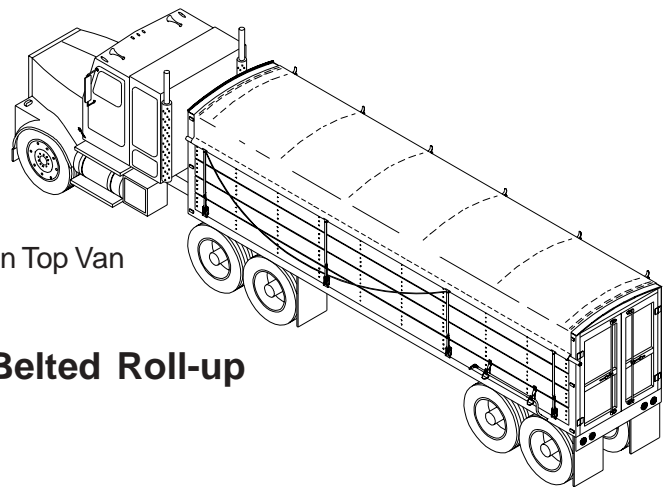

Premium Belted Roll-up

End Dump

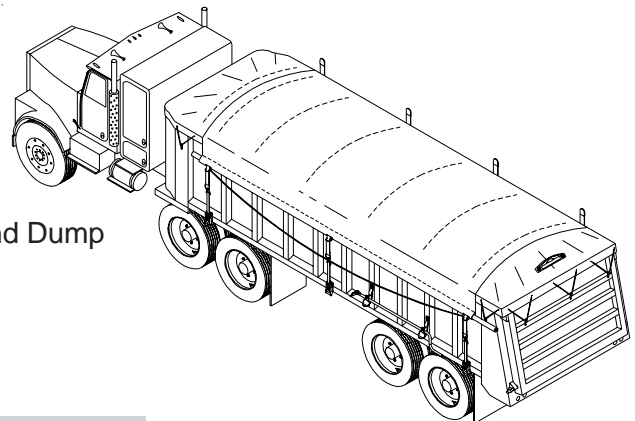

Shur-Co. of Illinois
4350 E Boyd Rd
I-72 Rt 48 Interchange
Decatur, IL 62521
Ph: 1-217-877-8277
Fax: 1-217-877-8270

Shur-Co. of Iowa - FD
3839 Midway Blvd
Ft. Dodge, IA 50501
Ph: 1-515-576-0959
Fax: 1-515-576-5578

MESSAGE TO OWNERS

Thank you for buying a Shur-Co. tarping system. We appreciate your confidence in our products. Please read and thoroughly understand this manual before installing and/or operating your tarping system.

Pay particular attention to important safety and operating instructions, as well as warnings and cautions. The hazard symbol  is used to alert users to potentially hazardous conditions, and is followed by caution, warning or danger messages.

Failure to READ & FOLLOW INSTRUCTIONS could result in failure of your tarping system and/or personal injury. Your trailer requirements may, however, call for minor variations to these instructions.

Please inspect your tarping system periodically. Repair or replace worn or damaged parts to your system.

QUESTIONS?

CALL OUR HELPLINE

1-800-4 SHUR-LOK
(1-800-474-8756)

8 AM - 5 PM MON - FRI CT

SAFETY

We, at Shur-Co. are concerned with your safety, and the safety of all those operating this system. Therefore, we have provided safety decals at various locations on your tarping system. Keep decals as clean as possible at all times. Replace any decal that has become worn or damaged, painted over or otherwise difficult to read. Replacement decals are available through Shur-Co. dealers.

SAFETY INSTRUCTIONS

- 1. Always wear safety glasses during installation.**
- 2. Keep body and clothing clear of moving parts.**
- 3. No other use of this system is authorized, except as designed.**
- 4. Do not walk or stand on end caps.**
- 5. Close tarp securely before traveling at highway speed.**

TABLE OF CONTENTS

Box Preparation	2
Hardware Identification	2
Fabric End Cap Option	3-5
Aluminum End Cap Option	6
Galvanized Steel End Cap Option	7
Easy-Off End Cap Option	8
Standard Bow Option	9
Value Series Bow Option	10
1" Ridge Strap Option	11
Ridge Rope Option	12
Tarp Installation - Fixed Tube	13
Tarp Installation - Standard Tarp Stop Option	14
Tarp Installation - Easy-Off Tarp Stop Option	15
PBR Strap/Cable Installation	16
Crank Arm Assembly	17
Removeable Crank Option	18
Fixed Crank Option	19
Stretch Cord Return for Fixed Crank Option	20
Maintenance & Operation	21
PBR Replacement Parts	22-28
Upgrades & Accessories	29

TOOLS REQUIRED

1. Welder
2. #3 Phillips Insert Bit or #3 Phillips Screw Driver
(Use with 13/64 drill bit)
3. Air or Electric Wrench With 9/16" Socket
4. 9/16" Combination Wrench
5. 3/8" Drill
6. 9/64" Drill Bit
7. 3/16" Drill Bit
8. 1/4" Drill Bit
9. 5/16" Drill Bit (for 3/8" Self-Tapping Screws)
10. 3/8" Drill Bit (for 3/8" Cap Screws)
11. 13/32" Drill Bit
12. Band Saw or Hack Saw
13. Grinder
14. Hammer
15. C-Clamps

RUST PREVENTION

To prevent rust, paint all exposed metal, such as weld seams, and/or metal exposed by grinding or cutting, with corrosion resistant paint.



HARDWARE IDENTIFICATION

A



1700084 - Self-Drilling Screw, #8 x 3/8"

G



1700408 - Hex Nut, 1/4"

N

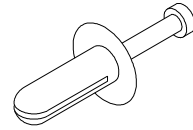

1700474 - Drive Rivet

B

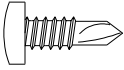

1700398 - Self-Drilling Screw, 1/4" x 3/4"

H

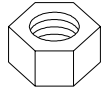

1700411 - Hex Nut, 5/16"

P



1700436 - Lock Washer, 1/4"

C

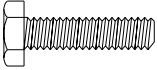

1700381 - Cap Screw, 1/4" x 1"

J



1700419 - Nylon Lock Nut, 5/16"

Q

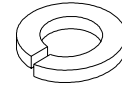

1700434 - Lock Washer, 3/8"

D

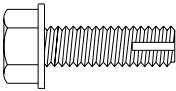

1701059 - Self-Drilling Screw, 5/16" x 1"

K

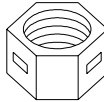

1700418 - Center Lock Nut, 3/8"

R

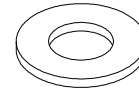

1701176 - Flat Washer, 3/8"

E

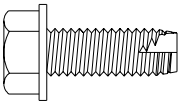

1700400 - Self-Tapping Screw, 3/8" x 1"

L

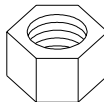

1700407 - Hex Nut, 3/8"

S

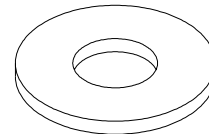

1700313 - Flat Washer, 1/2"

F

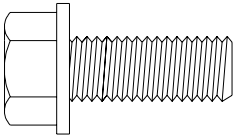

1702996 - Cap Screw, 1/2" x 1 1/4"

M

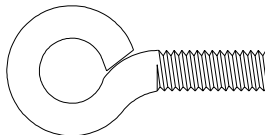

1700717 - Eyebolt Anchor, 5/16"

NOTE: Throughout this manual, where 3/8" x 1" self-tapping screws **E** are used with lock washers and nuts, use washers and nuts if possible, and drill 13/32" holes. Self-tapping screws used without washers and nuts require a minimum wall thickness of 3/16". Drill 5/16" holes.

TARP INSPECTION

Tarp length: Determine tarp length with slight tension applied. Compare actual tarp length with length stated on sheet attached to tarp. If tarp length does not match length on sheet, do not proceed. Call your local dealer, or call Shur-Co Customer Service at 1-800-474-8756.

BOX PREPARATION

Prepare your box before installing your Shur-Lok tarping system. Remove or grind any sharp edges smooth to prevent tarp damage. Fabricate additional framework if top rails have gaps that cannot be repaired.

To prevent rust, paint all exposed metal, such as weld seams, and/or metal exposed by grinding or cutting, with corrosion resistant paint.



CAUTION

Box extensions (tip tops), if used, must be secured to truck box. System could blow off if box extensions are not secured to box.

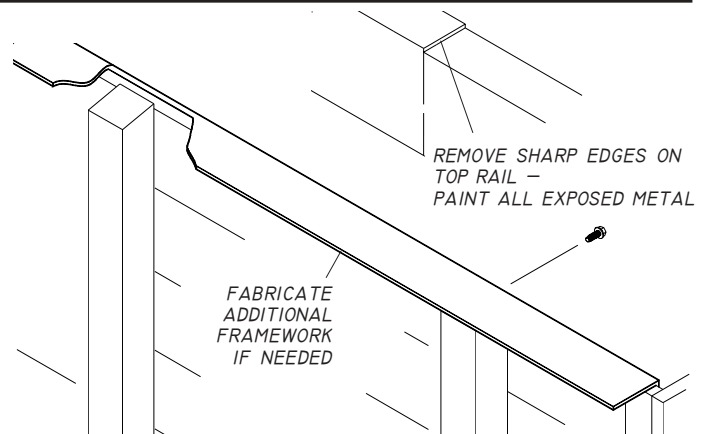

FABRIC END CAP OPTION

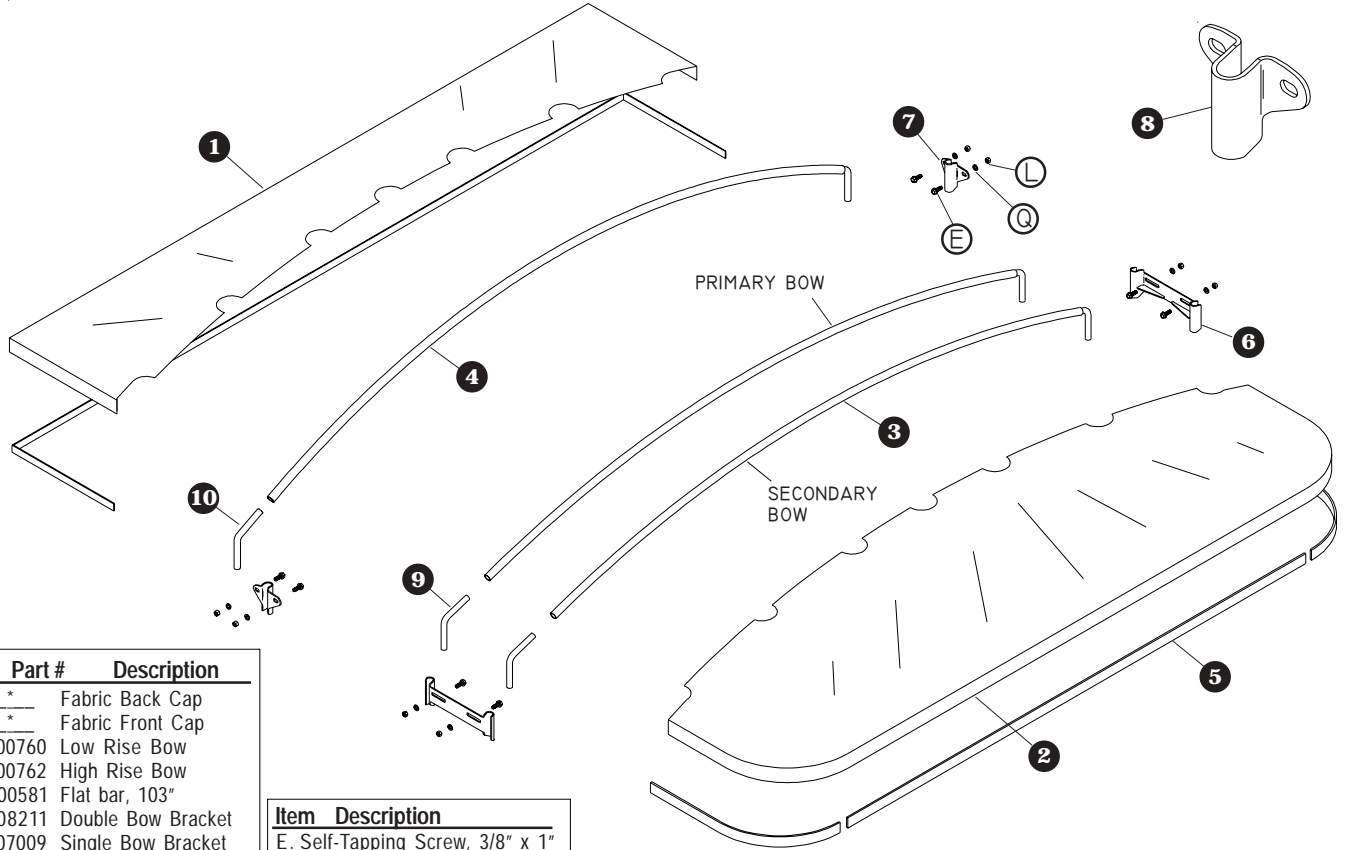

Item	Part #	Description
1.	*	Fabric Back Cap
2.	*	Fabric Front Cap
3.	1100760	Low Rise Bow
4.	1100762	High Rise Bow
5.	1700581	Flat bar, 103"
6.	1108211	Double Bow Bracket
7.	1107009	Single Bow Bracket
8.	1115702	Universal Bow Bracket
9.	1100695	Low Rise Bow Shank
10.	1106925	High Rise Bow Shank

Item	Description
E.	Self-Tapping Screw, 3/8" x 1"
L.	Hex Nut, 3/8"
Q.	Lock Washer, 3/8"
* Specify size	

STEP 1: Measuring from front of box, mark cap depth on both top rails per cap depth listed on cap tag.

NOTE: If fabric cap depth does not match cap depth listed on cap tag, do not proceed. Contact Shur-Co. for further instructions.

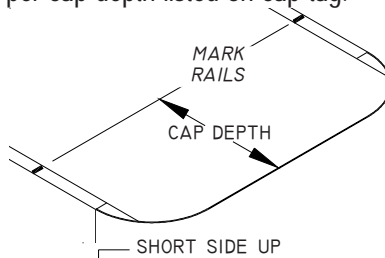

STEP 2: 1 1/2" - 3" wide rails: Position double bow brackets with short side up.

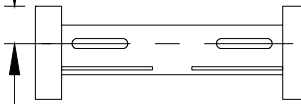

3" - 6" wide rails: Position double bow brackets with long side up.

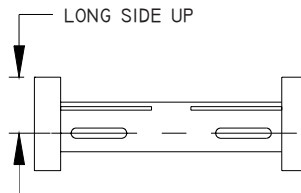

STEP 3: Position double bow brackets on rails with second mounting cavities centered on marks. Clamp brackets to rails.

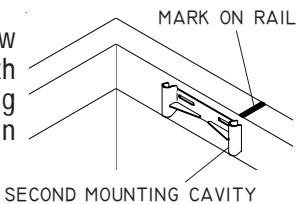

STEP 4: Place bow into bow bracket. Place loose bow shank in opposite bow bracket.

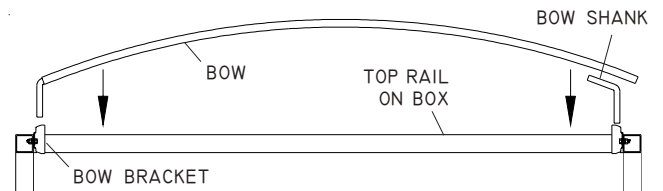

STEP 5: Align bow with bow shank. Mark bow at point where bend starts on shank. Cut both bows to this length.

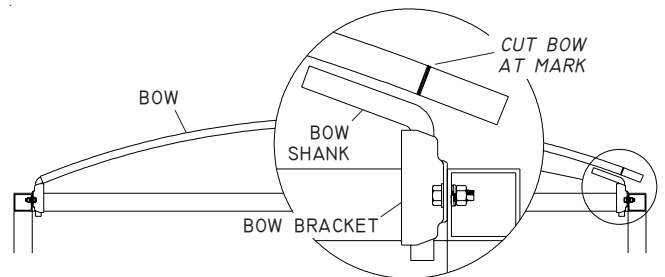

NOTE: Cut bows to exact length. Pressure from the tarp will cause short bows that are not welded to the shank to lose their arch.

STEP 6: Weld bow shank into secondary bow, leaving primary bow and shank unwelded. Insert secondary bow into first mounting cavities in bow brackets, and primary bow and shank into second mounting cavities.

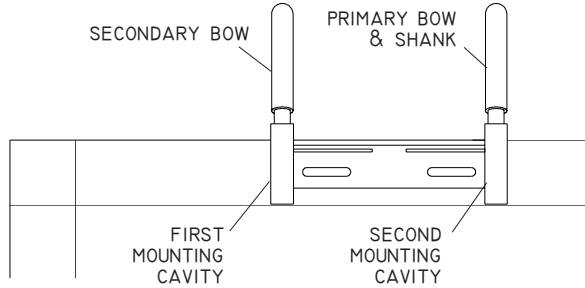

STEP 7: Adjust bow brackets vertically to achieve a distance of 3" - 6" between the bend in the bow shank and the point where the tarp will contact the bow.

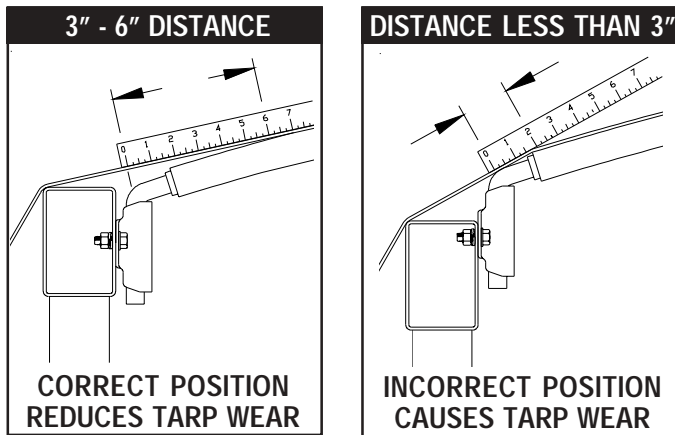

STEP 8: Mark and drill 5/16" holes, mount brackets with screws **E**, washers **Q**, and nuts **L**.

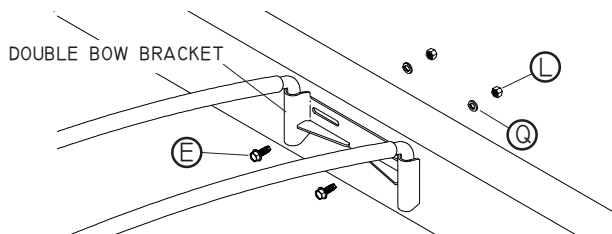

STEP 9: Remove primary bow shank from bow bracket and bow. Install fabric cap onto bow. Replace shank into bow and bow bracket. Allow front and sides of fabric cap to hang over edges of top rail on front of box.

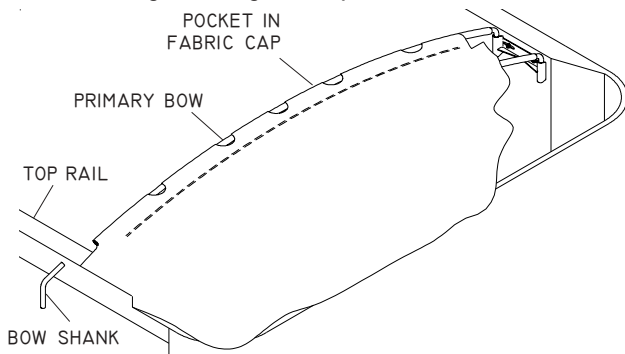

NOTE: Check your fabric cap for fit on your box, keeping in mind that inconsistencies in boxes may prevent a perfect fit.

STEP 10: Cut aluminum flat bar sections 1/2" shorter than pocket lengths. Insert sections into fabric cap pocket. Shape to fit corner radius if applicable.

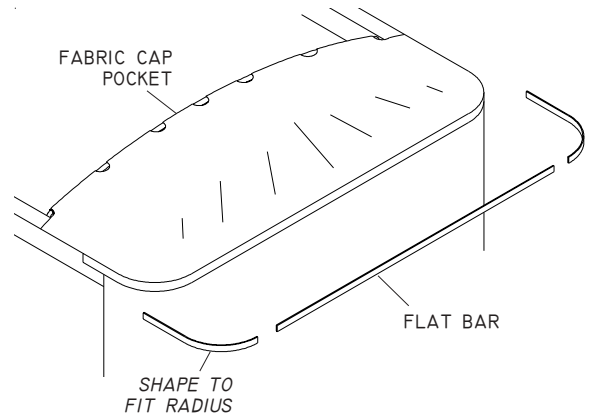

TIPS - Use one flat bar section across straight portion on front of cap. Side and radius may be one piece. Use as few pieces as possible. Create even tension on fabric cap for a secure and attractive fit.

STEP 11: Install rear bow in the same way as front bow, using single bow brackets, and single bow. Do not weld loose bow shank to bow.

NOTE: Install single bow bracket in same orientation as double bow bracket used on front cap.

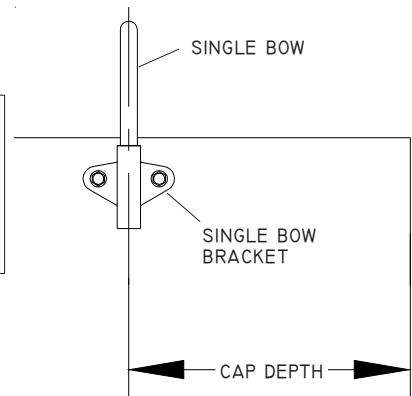

NOTE: Cut bows to exact length. Pressure from the tarp will cause short bows that are not welded to the shank to lose their arch.

STEP 12: Remove rear bow shank from bow bracket and bow, and slide fabric cap onto bow. Replace shank into bow and bow bracket. Install flat bar as in Step 10.

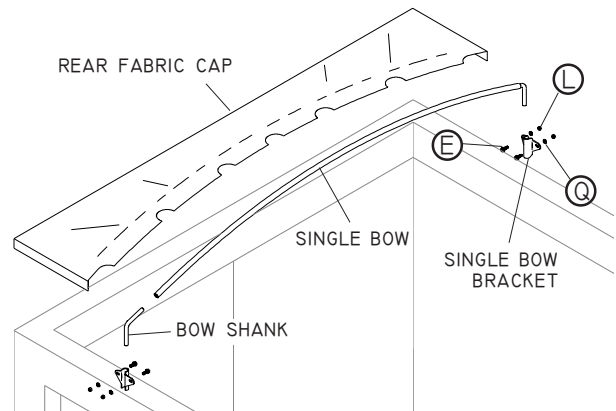

Item	Part #	Description
1.	1700990	Shock Cord, 18"
2.	1701355	Rope Anchor
D.		Self-Tapping Screw, 5/16" x 1"
E.		Self-Tapping Screw, 3/8" x 1"
J.		Nylon Lock Nut, 5/16"
L.		Hex Nut, 3/8"
Q.		Lock Washer, 3/8"

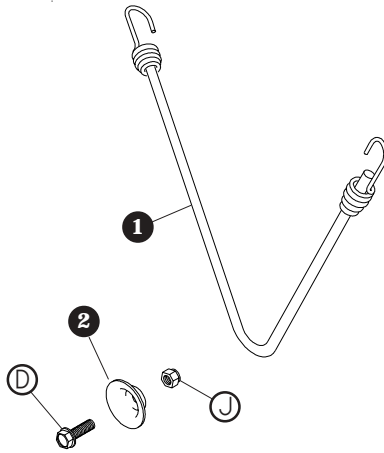

Front and sides of fabric caps may be fastened to box with shock cords and rope anchors to allow easy removal and replacement, or with self-tapping screws, lock washers and nuts.

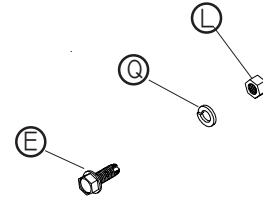

SHOCK CORD OPTION

STEP 1: Center shock cords on each side of cap. Drill 3/16" holes through aluminum flat bar and hook shock cords through holes.

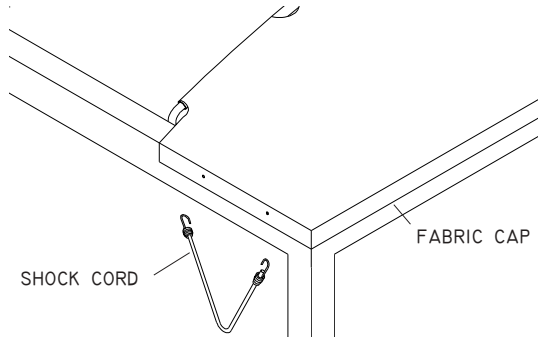

STEP 2: Equally space remaining shock cords across face of fabric cap. Drill 3/16" holes through aluminum flat bar and hook shock cords through holes.

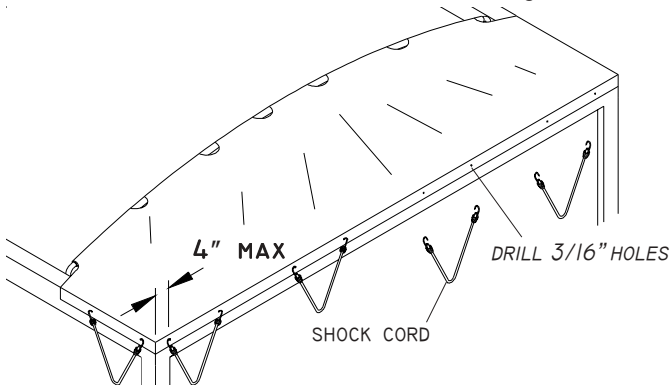

STEP 3: Locate rope anchors so that shock cords will receive at least 10 pounds of force pulling on them. Drill 1/4" holes and fasten rope anchors with screws **D** and nuts **J**.

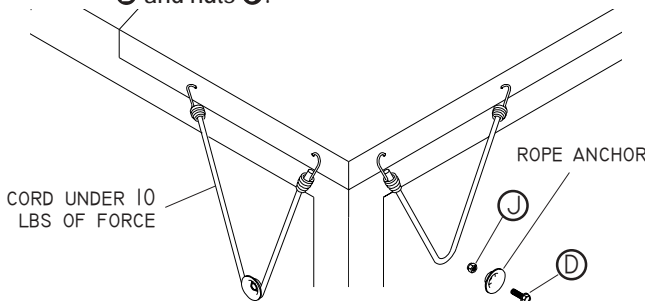

BOLT DOWN OPTION

STEP 1: Square up fabric caps on grain cart.

STEP 2: Measure and mark a minimum of five hole locations across front of fabric cap, starting 6" from each side of fabric cap, and equally spacing remaining holes.

STEP 3: Mark two hole locations on each side of fabric cap, centering holes approximately.

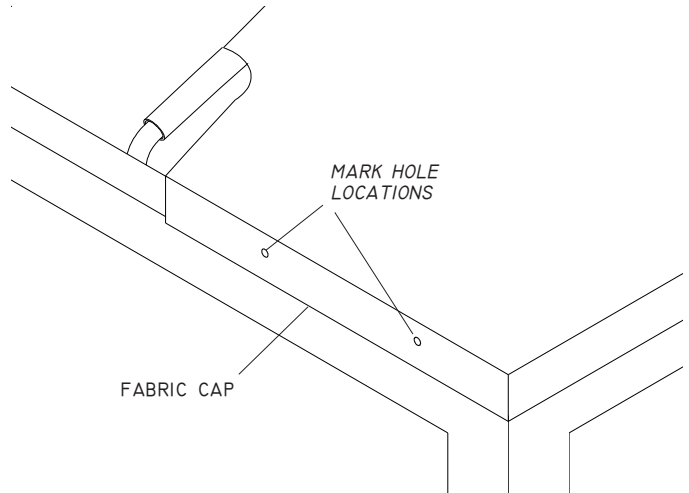

STEP 4: Drill 5/16" holes at marked locations through fabric cap, aluminum flat bar, and box. Fasten cap to box with screws **E**, washers **Q**, and nuts **L**.

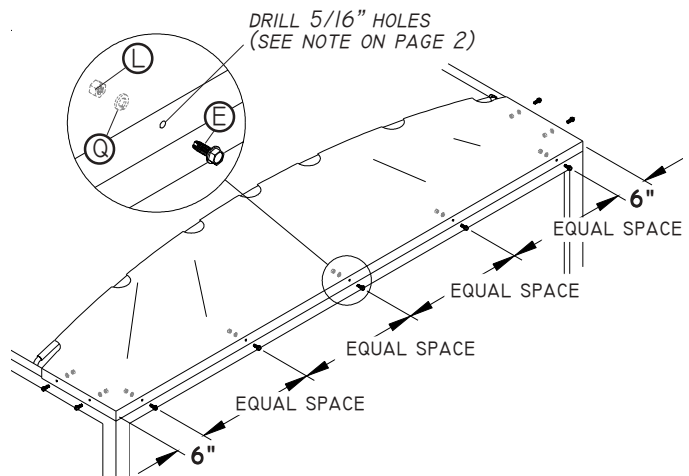

ALUMINUM END CAP OPTION

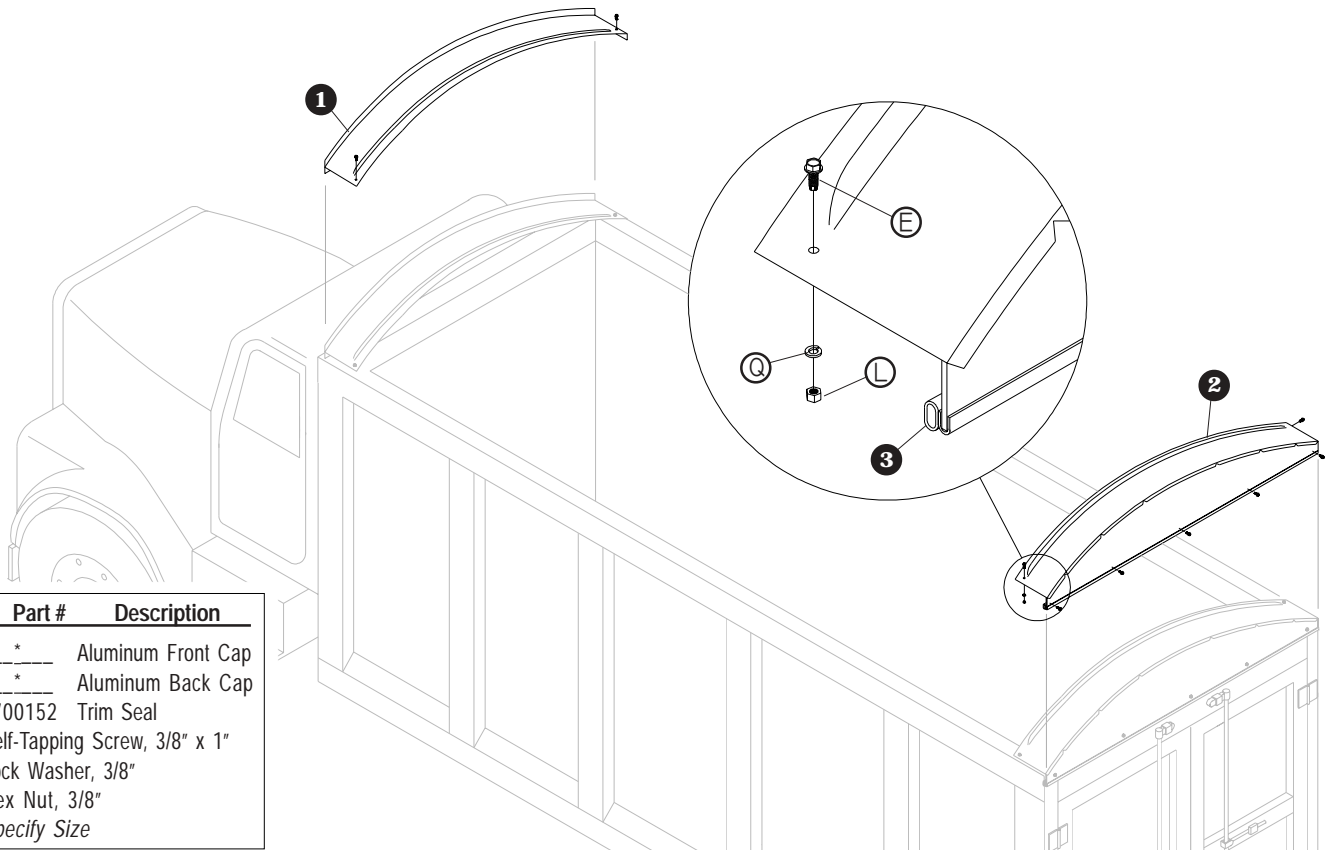

Item	Part #	Description
1.	___*	Aluminum Front Cap
2.	___*	Aluminum Back Cap
3.	1700152	Trim Seal
E.		Self-Tapping Screw, 3/8" x 1"
Q.		Lock Washer, 3/8"
L.		Hex Nut, 3/8"
* Specify Size		

STEP 1: Modify caps to fit: Place front cap with windshield on front of box. Place rear cap on rear of box. Modify caps to fit your box as required.

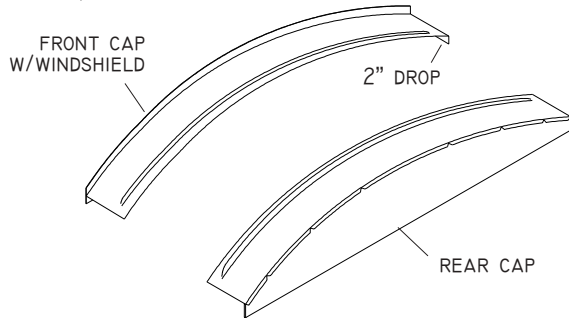

NOTE: To install your tarp to open from the passenger's side of the trailer (reverse roll), remove the 2" cap drop on the passenger side before installing caps.

STEP 2: Trim seal: Apply trim seal to caps, placing foam seal on inside of caps. Tap into place.

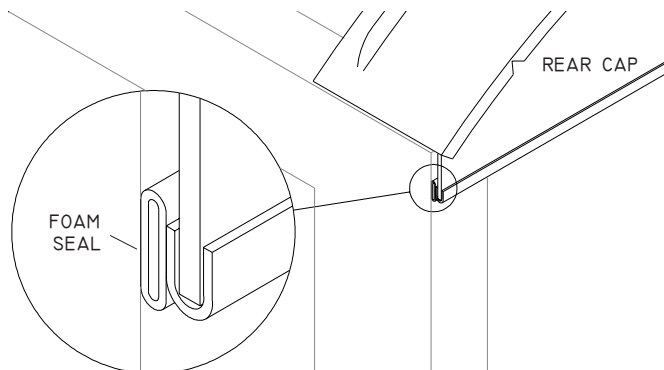

STEP 3: Install caps: Drill 5/16" hole and fasten screw **E**, washer **Q**, and nut **L** on cap drop near truss tube as shown.

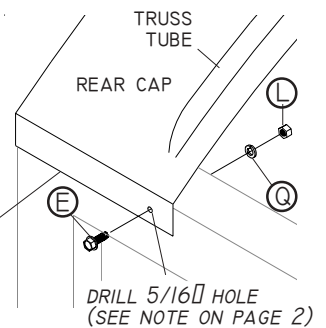

STEP 4: Evenly space five screws across face of cap. Mark and drill 5/16" holes, and fasten with screws **E**, washer **Q**, and nut **L**.

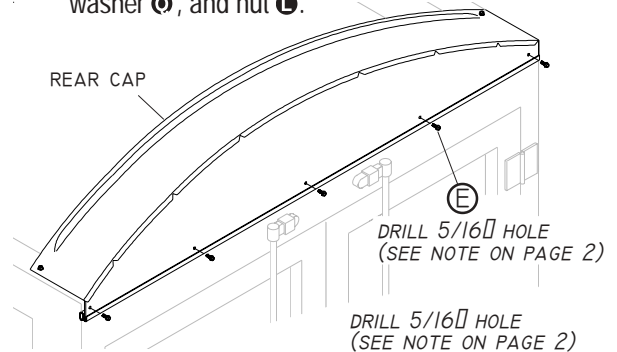

STEP 5: Drill 5/16" hole and fasten screw **E**, washer **Q**, and nut **L** as close as possible to truss tube on driver's side of cap.

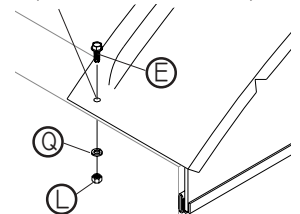

GALVANIZED STEEL END CAP OPTION

Item	Part #	Description
1.	1108977	Galvanized Low Rise Cap, 93"
	1108980	Galvanized Low Rise Cap, 95"
	1108983	Galvanized Low Rise Cap, 100"
	1108986	Galvanized High Rise Cap, 93"
	1108989	Galvanized High Rise Cap, 95"
	1108992	Galvanized High Rise Cap, 100"
	E.	Self-Tapping Screw, 3/8" x 1"
	Q.	Lock Washer, 3/8"
	L.	Hex Nut, 3/8"

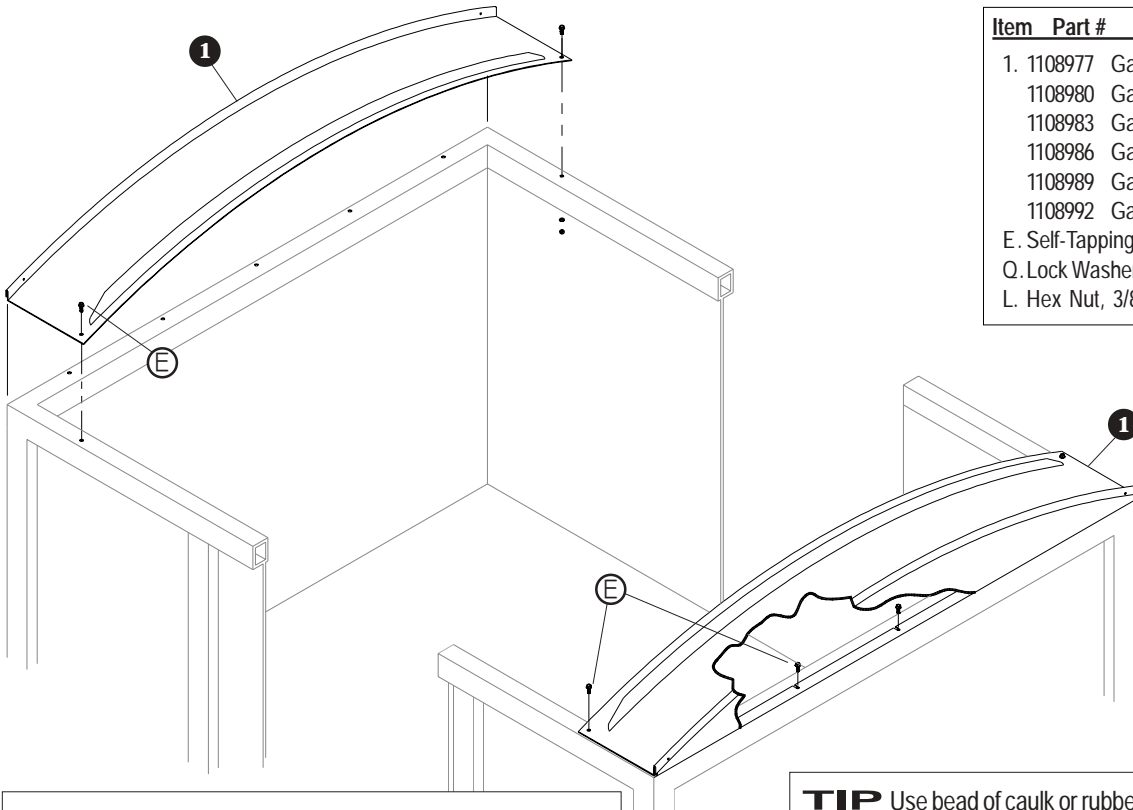

NOTE: End caps may need slight modifications to fit your box.

TIP Use bead of caulk or rubber seal where cap meets top rail to improve watertightness of end caps.

STEP 1: Center end caps on box. Mark hole locations on top rail using slots in cap as a template.

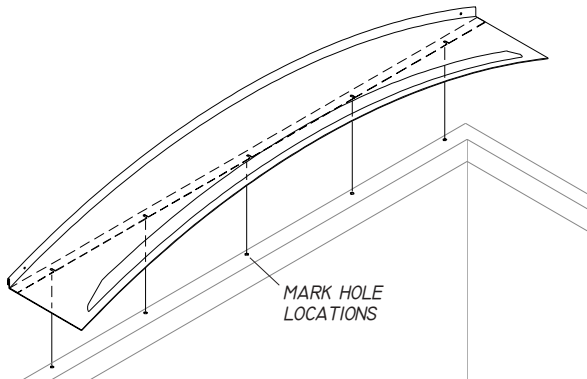

STEP 2: Drill 5/16" holes at marked locations on top rail. Fasten end cap to rail with screws (E), washers (Q), and nuts (L).

TIP Thread 3/8" x 1" self-tapping screws into top rail, back screws partially out, slide cap into place and tighten screws.

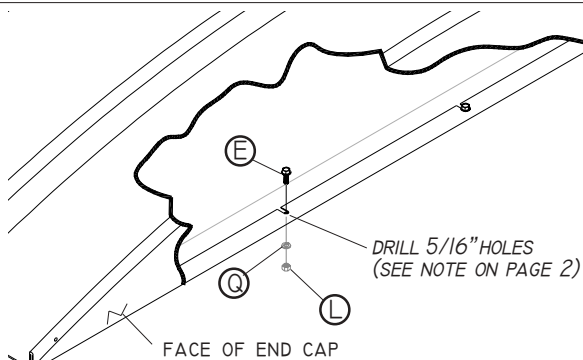

STEP 3: Drill two 5/16" holes, as close as possible to truss tube, through end cap and top rail.

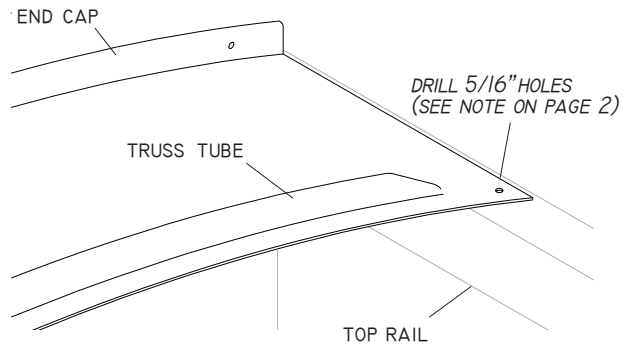

STEP 4: Fasten with screws (E), washers (Q), and nuts (L).

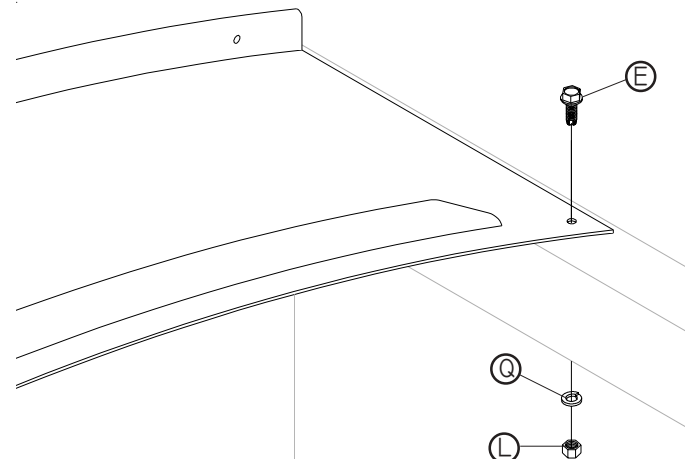

EASY-OFF END CAP OPTION

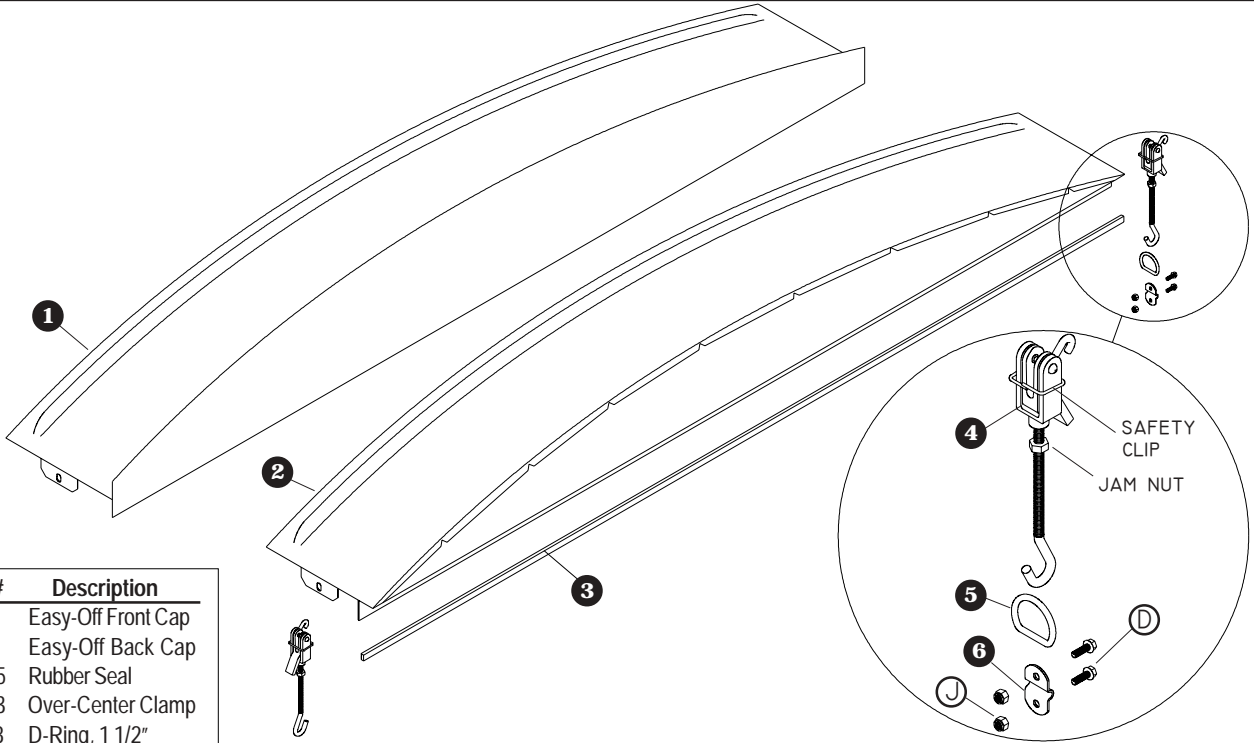

Item	Part #	Description
1.	*	Easy-Off Front Cap
2.	*	Easy-Off Back Cap
3.	1701115	Rubber Seal
4.	1701113	Over-Center Clamp
5.	1701218	D-Ring, 1 1/2"
6.	1701114	D-Ring Bracket
D.		Self-Tapping Screw, 5/16" x 1"
J.		Nylon Lock Nut, 5/16"
* Specify Size		

⚠ CAUTION
Secure safety clips around clamps before driving vehicle.

STEP 1: Deburr rough edges on truck and clean area thoroughly before applying rubber seal.

STEP 2: Apply rubber seal to front cap.

STEP 3: Place front cap on box.

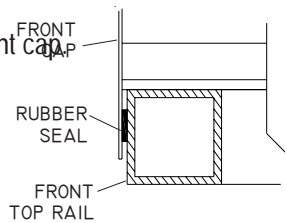

NOTE: Do not apply rubber seal in temperatures below 60° F or above 100° F, or adhesive may fail. Apply seal without stretching.

STEP 4: Locate clamps in area free from obstructions, offset D-ring 1/2" from center of cap.

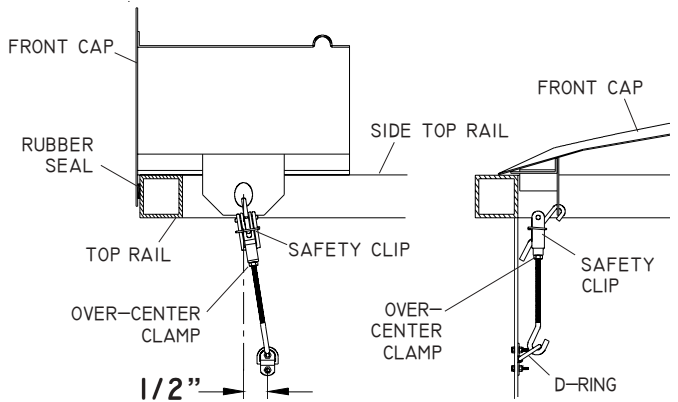

STEP 5: Mark and drill 1/4" holes. Fasten D-Ring plates to box with screws D, and nuts J. Tighten jam nut against clamp body and position safety clip.

STEP 6: Place rear cap on box. Notch inside drop to allow 1/8" clearance on both sides of top rail.

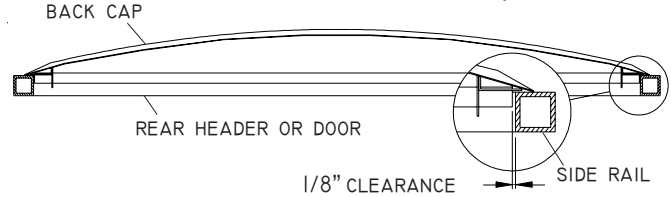

STEP 7: Remove cap, apply rubber seal 1/4" down from flat portion of cap above drop.

STEP 8: Replace cap, locate over-center clamps in area free from obstructions, and offset D-ring 1/2" from center of cap.

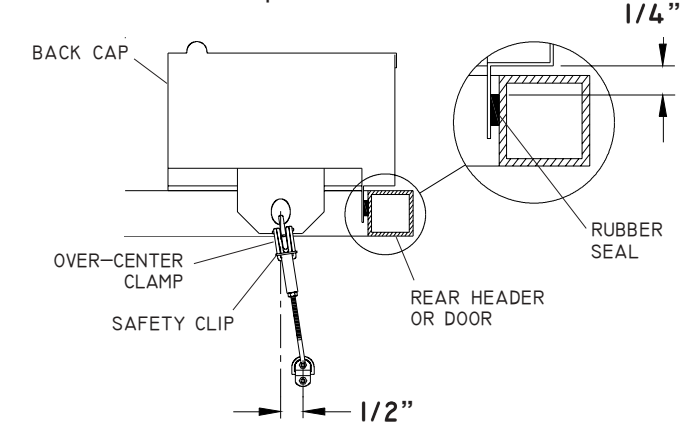

STEP 9: Mark and drill 1/4" holes. Fasten D-ring plate to box with screws D, and nuts J. Tighten jam nut against clamp body and position safety clip.

STANDARD BOW OPTION

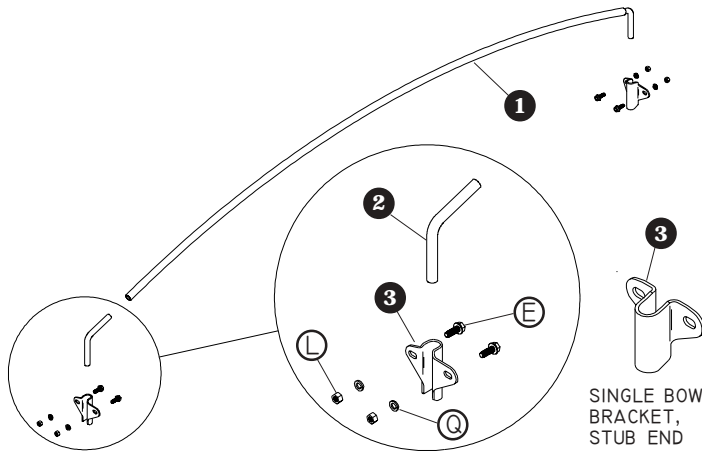

Item	Part #	Description
1.	1100760	Std. Low Rise Bow
	1100762	Std. High Rise Bow
	1109149	Std. Flat Bow
2.	1100695	Low Rise Bow Shank
	1106925	High Rise Bow Shank
	1109150	Flat Bow Shank
3.	1107009	Single Bow Bracket
	1115702	Universal Bow Bracket
	E.	Self-Tapping Screw, 3/8" x 1"
	L.	Hex Nut, 3/8"
	Q.	Lock Washer, 3/8"

STEP 1: Mark bow bracket locations on top rails, between end caps as shown.

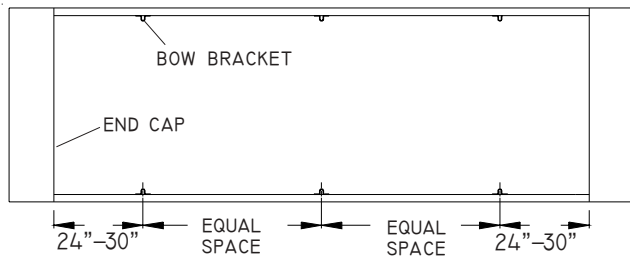

STEP 2: 1 1/2" - 3" wide rails:
Position single bow brackets with short side up.

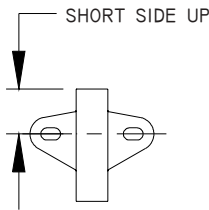

3" - 6" wide rails:
Position single bow brackets with long side up.

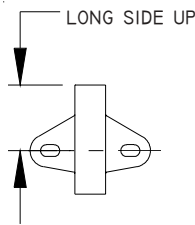

STEP 3: Align center of brackets with mark. Clamp brackets to rails.

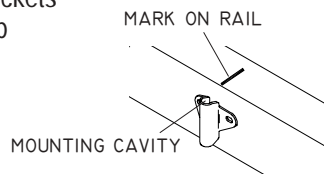

STEP 4: Place bow into bow bracket. Place loose bow shank in opposite bow bracket.

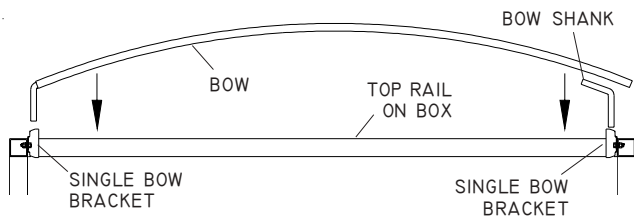

STEP 5: Align bow with bow shank. Mark and cut bow at point where bend starts on shank. Grind edges smooth, and weld shank to bow.

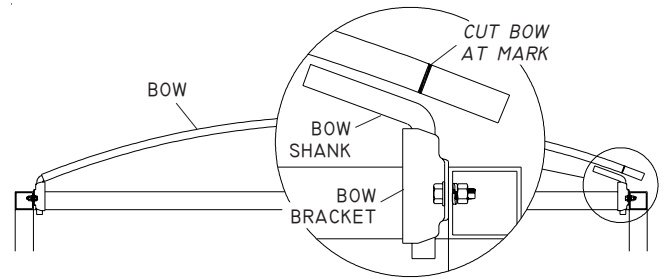

NOTE: Shanks must be welded to bows.

STEP 6: Adjust bow brackets vertically to create a distance of 3" - 6" between the bend in the bow shank and the point where the tarp will contact the bow.

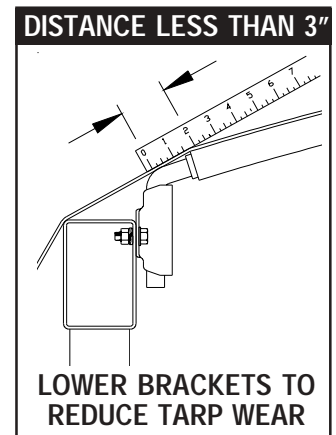
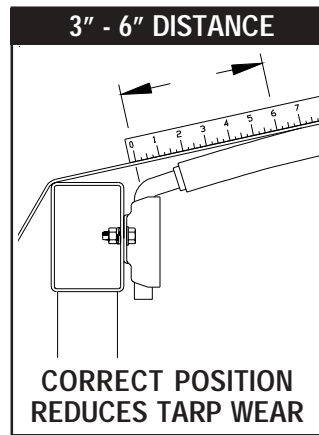

STEP 7: Mark and drill 5/16" holes, mount brackets with screws E, washers Q, and nuts L. Install bows into bow brackets.

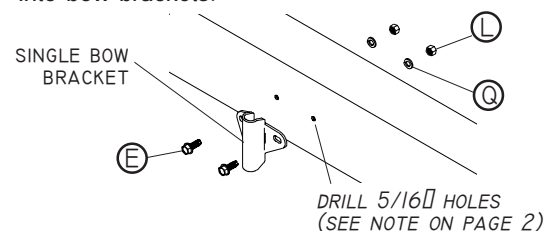

VALUE SERIES BOW OPTION

Item	Part #	Description
1.	1108548	Value Series Low Rise Bow
	1108549	Value Series High Rise Bow
2.	1108550	Value Series Bow Shank
B.		Self-Drilling Screw, 1/4" x 3/4"
E.		Self-Tapping Screw, 3/8" x 1"
L.		Hex Nut, 3/8"
Q.		Lock Washer, 3/8"

USED IN FARM BODY APPLICATIONS

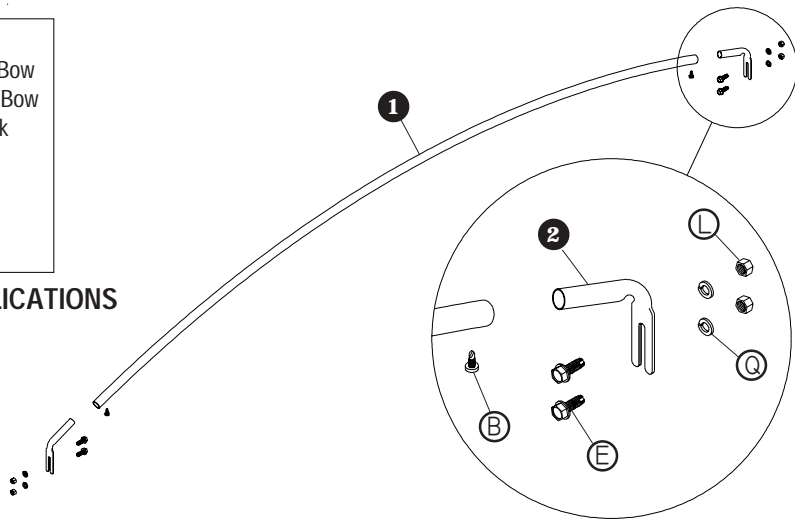

NOTE: On top rails less than 4" deep, locate bow brackets on vertical box supports, or provide additional bracketry.

STEP 1: Align bows on top rail as shown, mark bow locations.

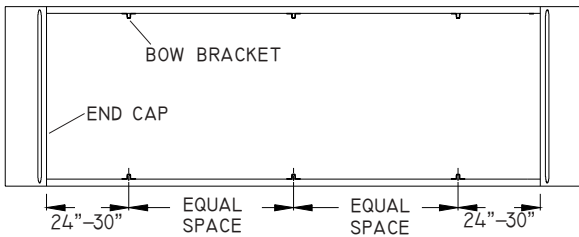

STEP 2: Align bow shanks at marked location, mark and drill 5/16" holes on inside top rail at 1 5/8" and 3 5/8" below top.

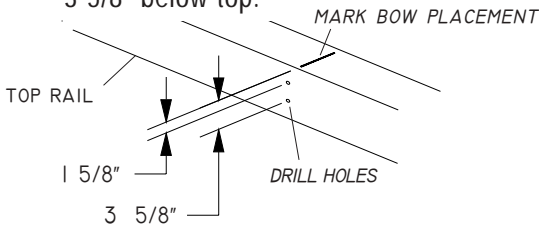

STEP 3: Secure bow shank to driver side top rail with screws E.

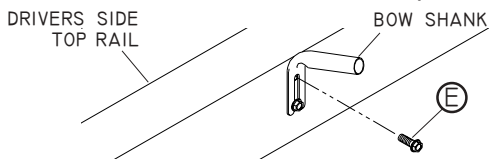

STEP 4: Insert screw E halfway into drilled hole on passenger side top rail and slide bow shank in place, but leave screw loose.

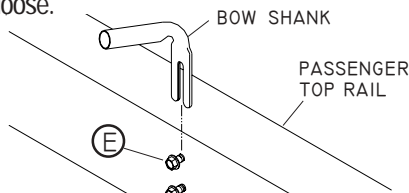

STEP 5: Slide bow over driver side bow shank.

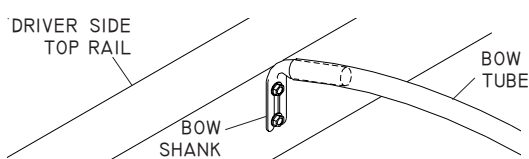

STEP 6: Align loose end of bow with opposite bow shank on passenger side top rail. Adjust angle of shank.

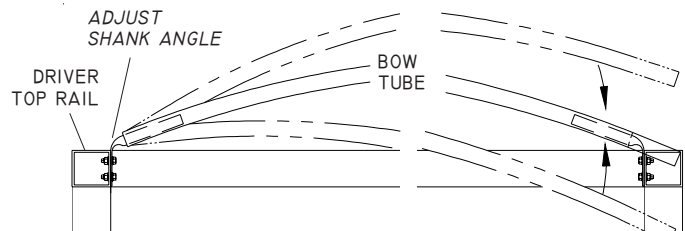

STEP 7: Mark and cut bow tube at bend on bow shank.

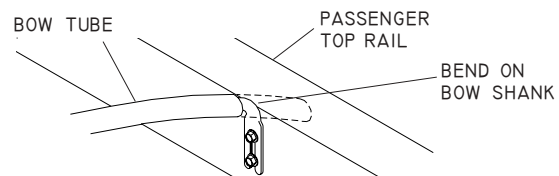

STEP 8: Insert passenger side bow shank into bow.

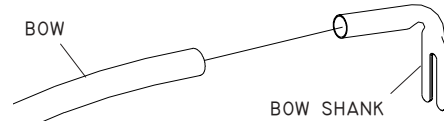

STEP 9: Insert bow and shank over screws on passenger side top rail. Adjust neck angle, and tighten screws.

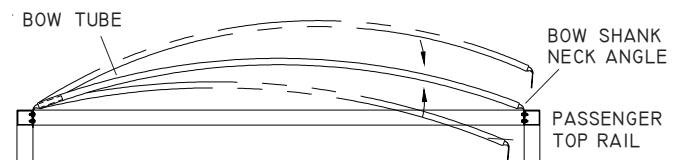

STEP 10: Fasten ends of bow to bow shanks with screws B.

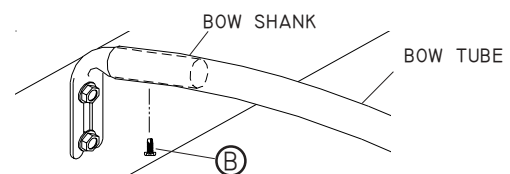

NOTE: Bows may be welded to shanks, or fastened with screws as shown. Do not leave bows unfastened to shanks, or pressure from tarp could cause bows to lose their arch.

1" RIDGE STRAP OPTION

POSITION RATCHET HANDLE UNDER RIDGE STRAP TO PREVENT TARP WEAR

Item	Part #	Description
1.	1101680	Ridge Strap w/Anchor, 1" x 25'-0"
2.	1101678	Ratchet w/1" Ridge Strap & Anchor
3.	1700836	Ratchet for 1" Ridge Strap
4.	1101683	Anchor Bushing
	E.	Self-Tapping Screw, 3/8" x 1"
	R.	Flat Washer, 3/8"
	K.	Centerlock Nut, 3/8"

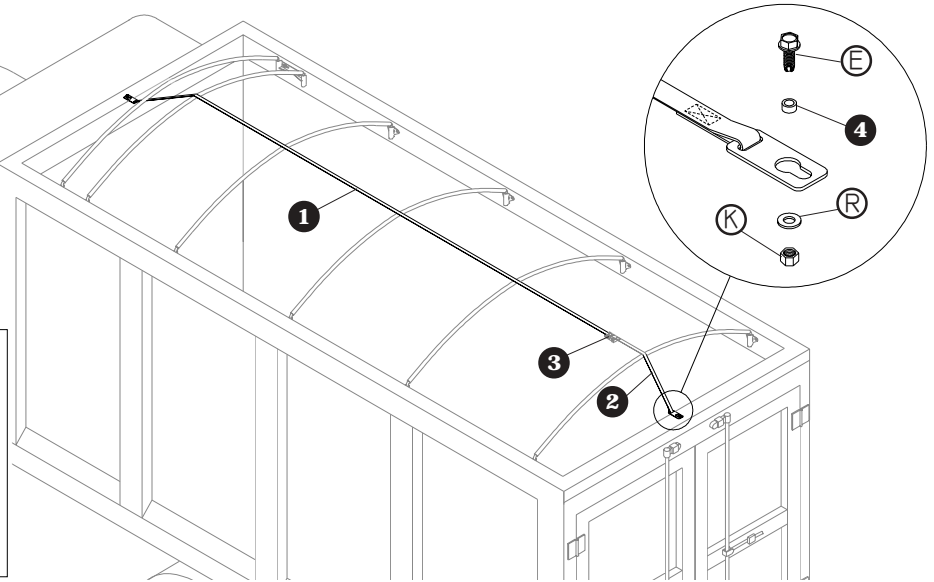

STEP 1: Mark hole locations for ridge strap anchor supports.
Aluminum/steel caps: Fasten ridge strap anchor supports to end caps.
Fabric Caps: Fasten ridge strap anchor supports to top rail.

Boxes up to 8 1/2 ft. wide: Mark and drill holes centered on front and rear top rails or end caps.

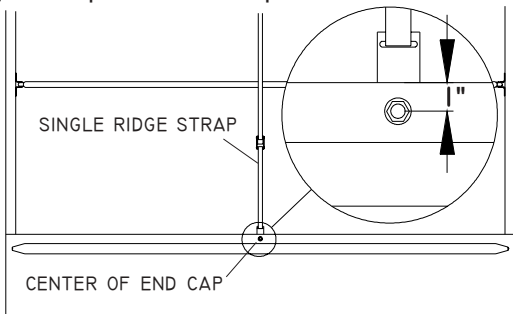

Boxes over 8 1/2 ft. wide: Mark and drill holes 20" apart centered on front and rear top rails or end caps.

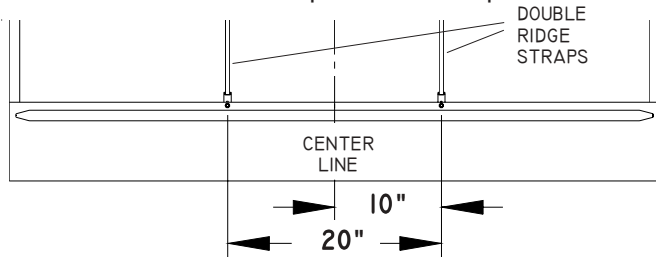

STEP 2: Mount ridge strap anchor bushings with screws **E**, washers **R**, and nuts **K**.

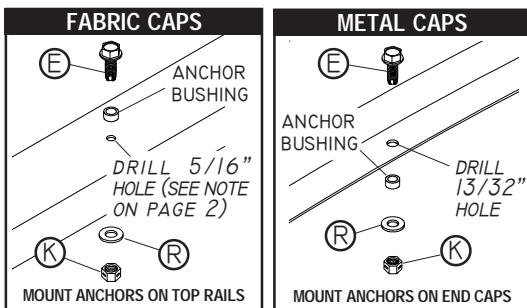

STEP 3: Place ridge straps over bows, positioning ratchet below strap as shown, and strap under first bow if using front fabric cap.

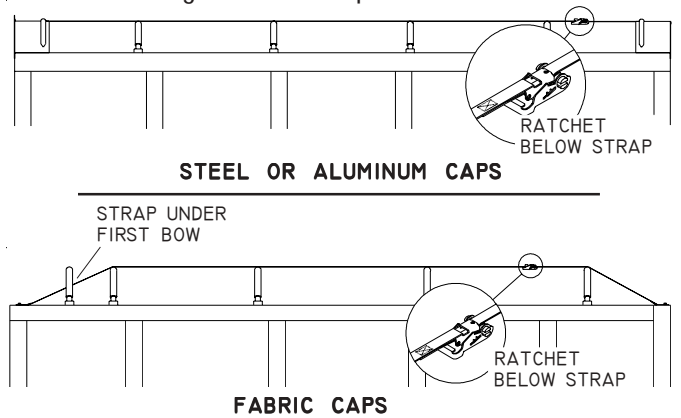

STEP 4: Hook ridge strap anchors over bushings at front and rear of box.

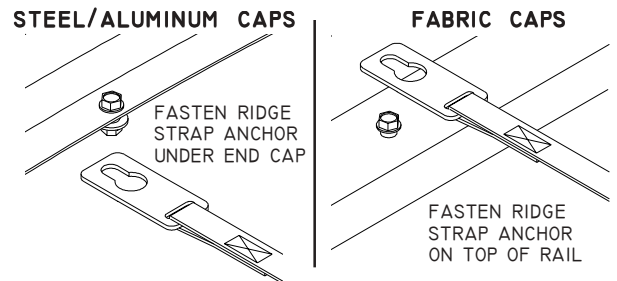

STEP 5: Thread strap through ratchet and tighten.

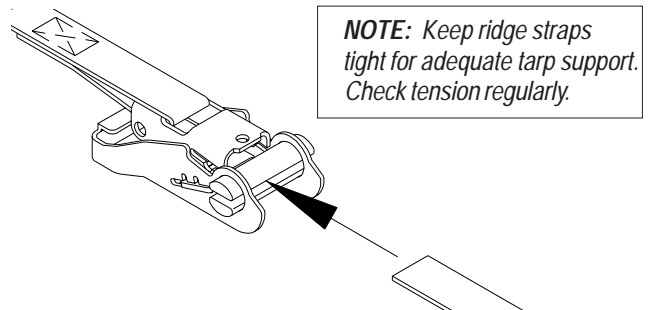

NOTE: Keep ridge straps tight for adequate tarp support. Check tension regularly.

RIDGE ROPE OPTION

USED IN FARM BODY APPLICATIONS

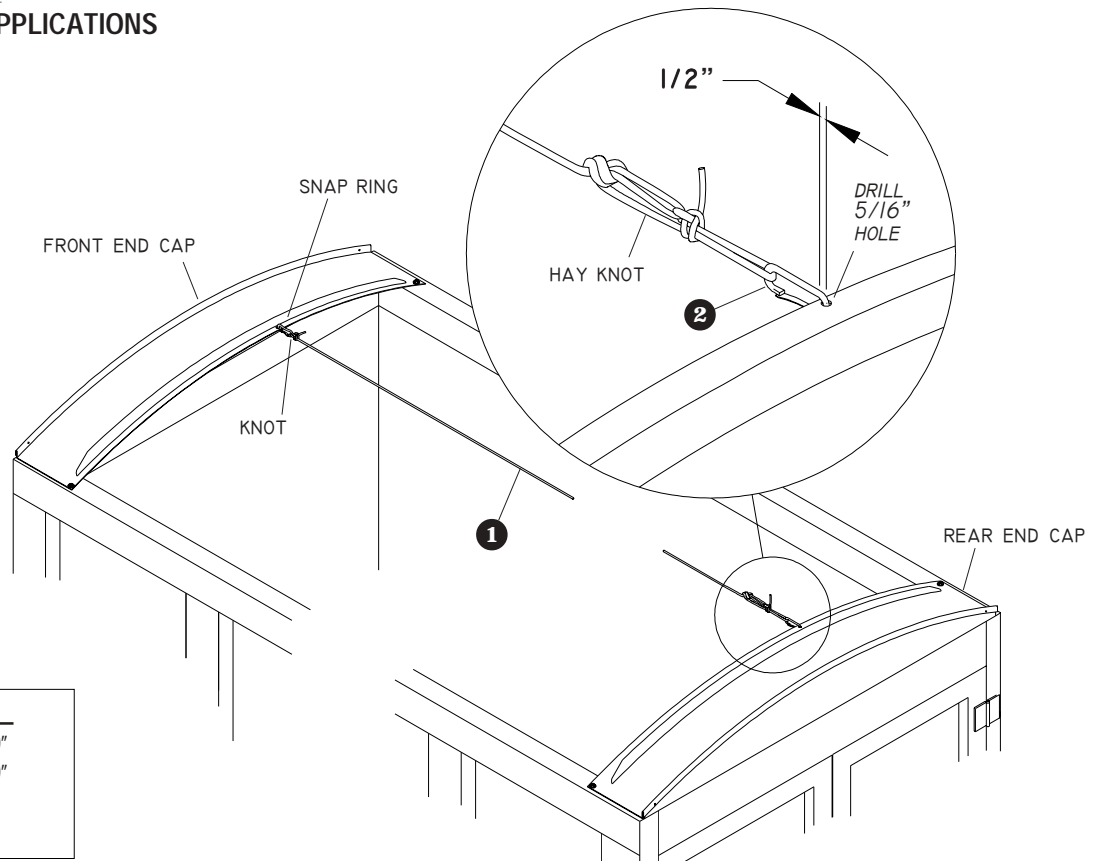

Item	Part #	Description
	1108573	Ridge Rope Kit, 30'-0"
	1108957	Ridge Rope Kit, 50'-0"
1.	1700624	Polyester Rope, 1/4"
2.	1700666	Wire Snap

STEP 1: Drill 5/16" holes in center of front and rear caps, then fasten snap rings into holes.

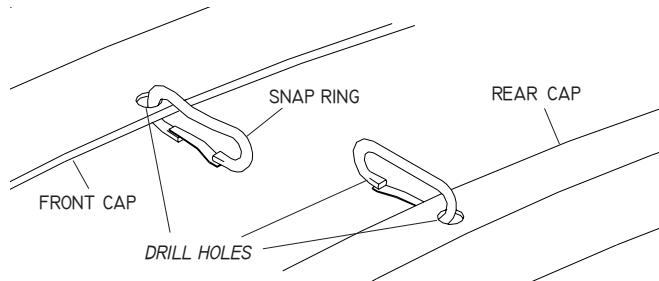

STEP 2: Insert end of rope through snap ring on front end cap and secure with knot.

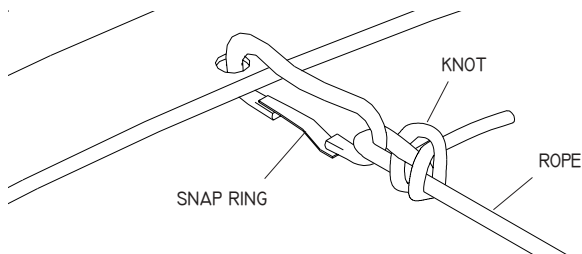

STEP 3: 12" from rear snap ring, tie a hay knot with a 2"-3" loop.

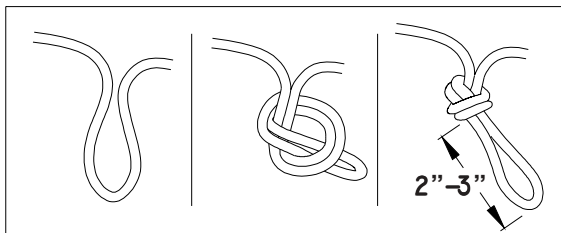

STEP 4: Pull rope through snap ring on rear cap, then through hay knot.

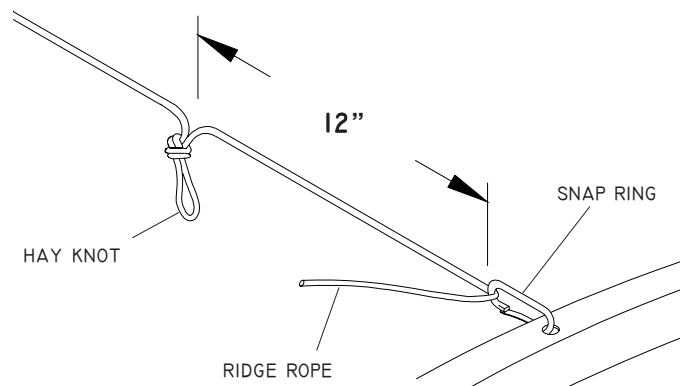

STEP 5: Pull ridge rope tight, and secure with knot.

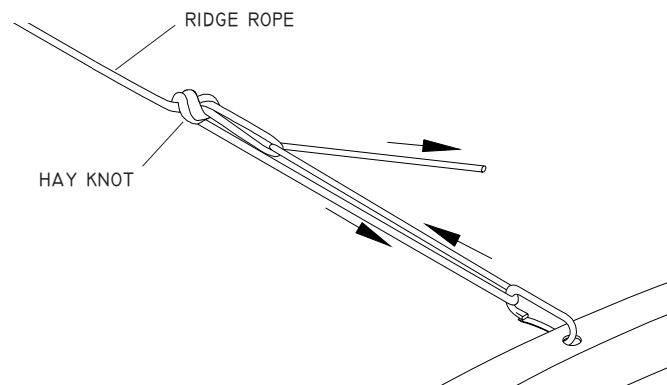

TARP INSTALLATION - FIXED TUBE

See Page 16 for U-Clamp Installation

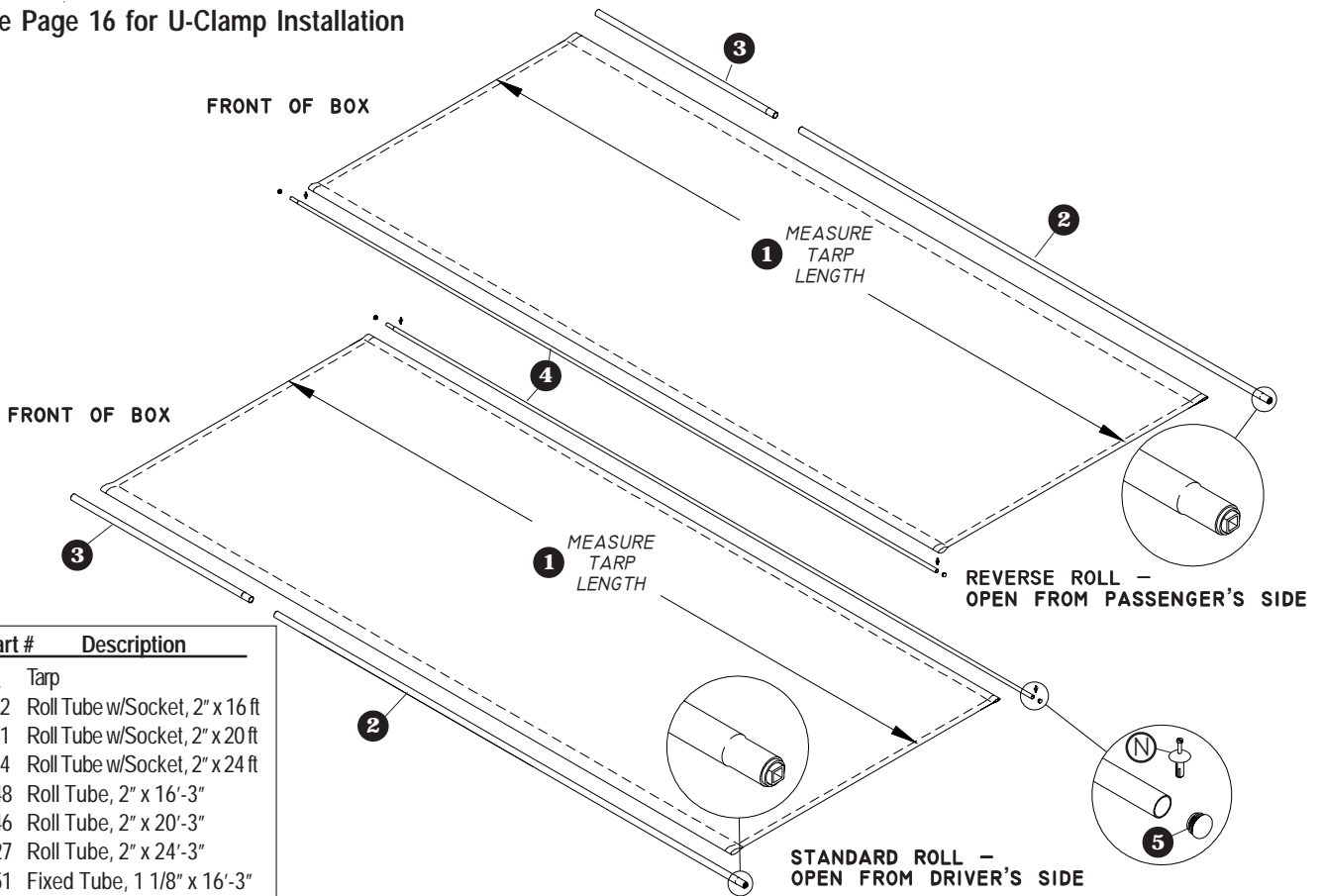

Item	Part #	Description
1.	*	Tarp
2.	1105132	Roll Tube w/Socket, 2" x 16 ft
	1105131	Roll Tube w/Socket, 2" x 20 ft
	1105124	Roll Tube w/Socket, 2" x 24 ft
3.	1700048	Roll Tube, 2" x 16'-3"
	1700046	Roll Tube, 2" x 20'-3"
	1701427	Roll Tube, 2" x 24'-3"
4.	1700051	Fixed Tube, 1 1/8" x 16'-3"
	1700049	Fixed Tube, 1 1/8" x 20'-3"
	1701428	Fixed Tube, 1 1/8" x 24'-3"
5.	1700523	Plastic End Plug
	N.	Drive Rivet, 1/4" x 3/4"
* Specify box length and width		

STEP 1: Open tarp, and stretch tight. Measure tarp length, and compare with tarp length specified on sheet attached to tarp. Do not proceed with installation if tarp length doesn't match length specified on sheet. Call Shur-Co. or your local dealer for alterations or a replacement tarp.

NOTE: Tarps cannot be returned at Shur-Co.'s expense beyond this point. Damaged tarps may be returned for repair or replacement at owner's expense.

STEP 2: Cut fixed tube 2" longer than tarp, removing swaged end. Grind cut edge smooth.

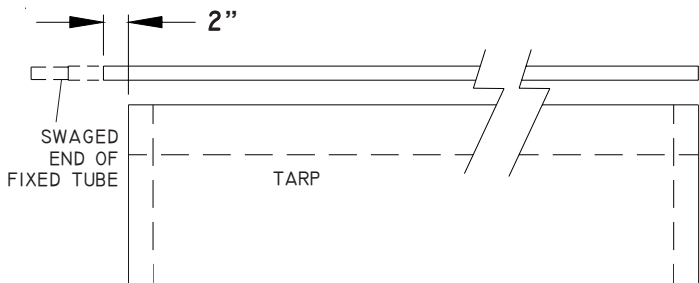

STEP 3: Install end plugs into ends of fixed tube.

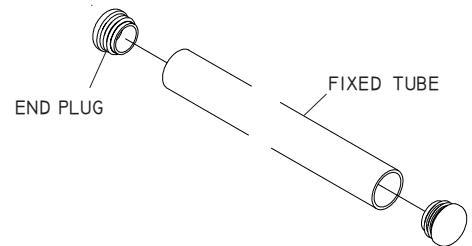

STEP 4: Insert fixed tube into 4" tarp pocket. Extend tube 1" past tarp edge, drill 1/4" hole, and secure with rivet N.

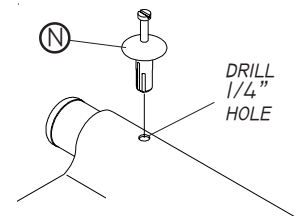

STEP 5: Stretch tarp along fixed tube, drill 1/4" hole, and secure second rivet on other end of fixed tube.

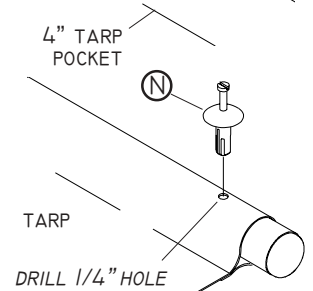

TARP INSTALLATION - *continued*

STEP 6: Insert roll tube into 5" tarp pocket with square key at rear of tarp.



TIP - Inflate 5" tarp pocket with air chuck while inserting roll tube.

STEP 7: Wind tarp completely around roll tube, then lift rolled up tarp assembly onto fixed tube side of box.

STEP 8: Center tarp on box, overlapping end caps 6"-9", with fixed tube hanging over edge of box. Square up tarp and fixed tube.

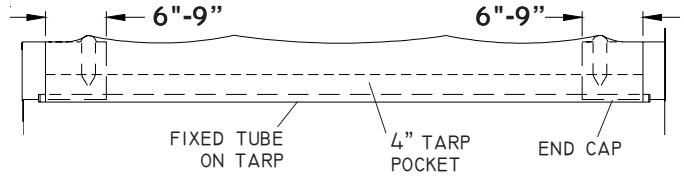

TARP INSTALLATION - STANDARD TARP STOP OPTION

Item	Part #	Description
1.	1700729	Protective Cap
2.	1100049	Standard Tarp Stop
3.	1100392	Offset Tarp Stop
4.	1105163	Recessed Tarp Stop
E.		Self-Tapping Screw, 3/8" x 1"
Q.		Lock Washer, 3/8"
L.		Hex Nut, 3/8"

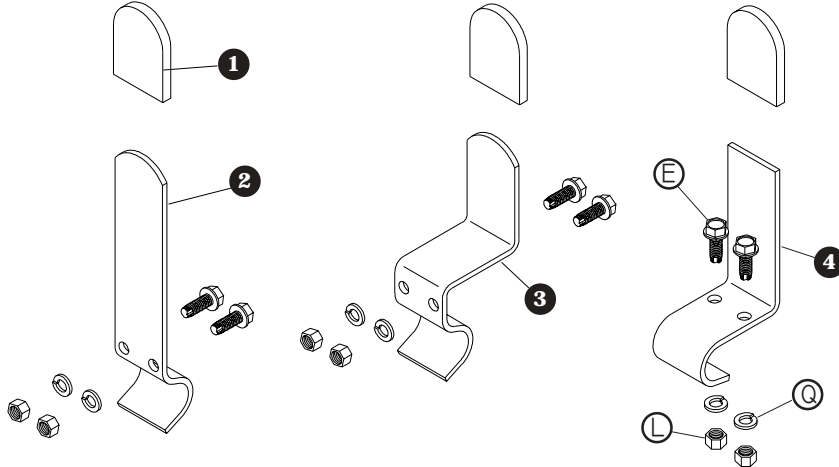

STEP 1: Locate first tarp stop 14"-18" from rear edge of tarp. Mark and drill holes. Hook tarp stop over fixed tube, and fasten to box with screws **E**, lock washers **Q**, and nuts **L**.

NOTE: Refer to note under Hardware Identification on Page 2, for drill size.

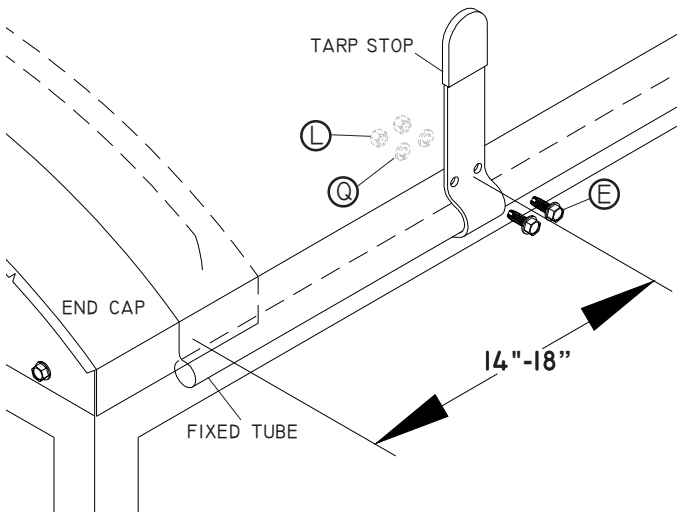

STEP 2: Square up tarp on box. Locate second tarp stop 14"-18" from front edge of tarp. Mark and drill holes. Hook tarp stop over fixed tube, and fasten to box with screws **E**, lock washers **Q**, and nuts **L**.

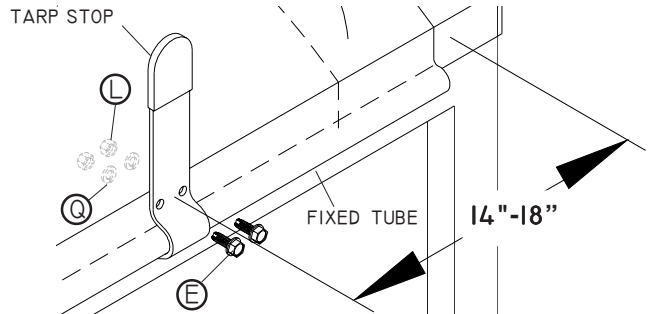

STEP 3: Equally space remaining tarp stops. Mark and drill holes and fasten to box with screws **E**, lock washers **Q**, and nuts **L**.

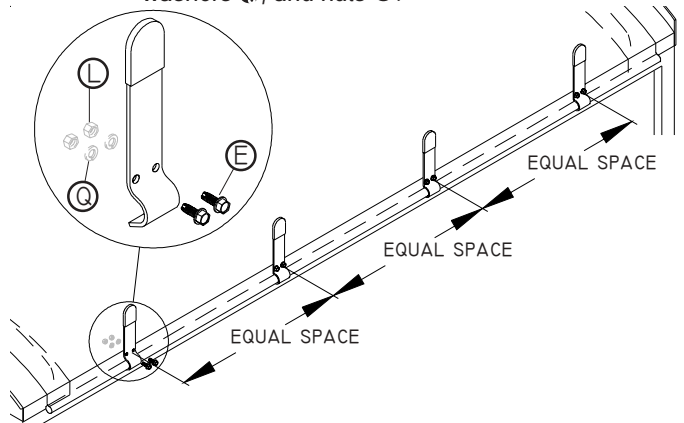

TARP INSTALLATION - EASY-OFF TARP STOP OPTION

Item	Part#	Description
1.	1100834	Easy-Off Cast Aluminum Tarp Stop Upright
2.	1105168	Easy-Off Cast Aluminum 6" Offset Tarp Stop Upright
3.	1115216	Easy-Off Flexible Tarp Stop Upright w/Plate
4.	1115217	Easy-Off Flexible 6" Offset Tarp Stop Upright w/Plate
5.	1100833	Easy-Off Tarp Stop Body
6.	1700799	Kickout Ring, 1"
7.	1700044	Clevis Pin, 5/16" x 2 7/8"
E.		Self-Tapping Screw, 3/8" x 1"
Q.		Lock Washer, 3/8"
L.		Hex Nut, 3/8"

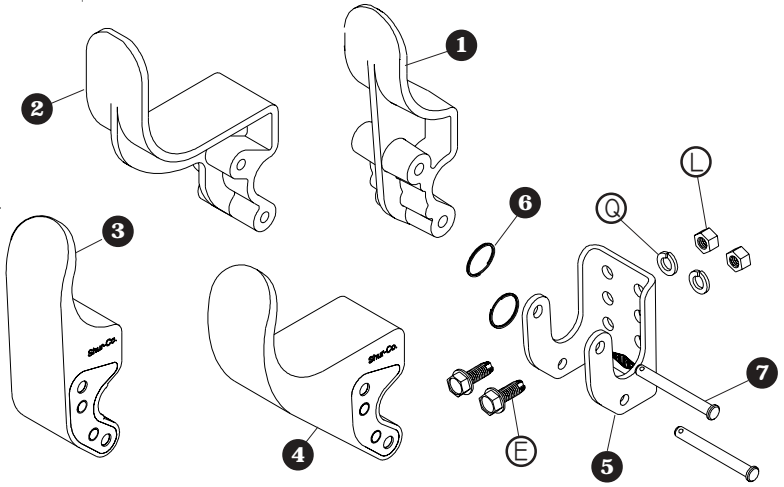

STEP 2: Locate first tarp stop body 14"-18" from front edge of fixed tube, and 1 1/4" below top of side rail. Mark and drill holes, and fasten to box with screws **E**, lock washers **Q**, and nuts **L**.

NOTE: Refer to note under Hardware Identification on Page 2, for drill size.

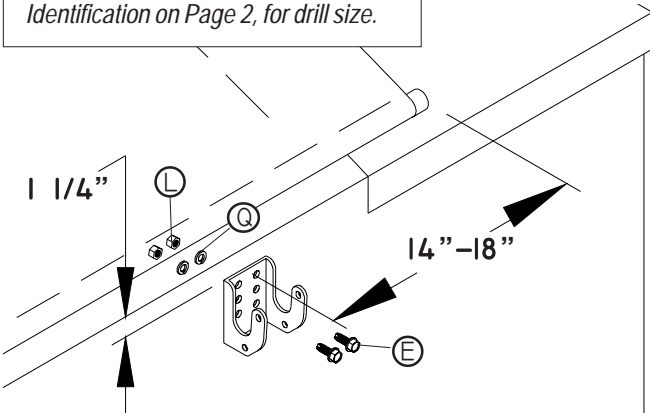

NOTE: Install tarp stop body on a vertical surface. Fasten through pair of holes that best fit your top rail configuration.

STEP 3: Square up tarp along length of box. Locate second tarp stop body 14"-18" from rear edge of fixed tube, and 1 1/4" below top of side rail. Mark and drill holes, and fasten to box with screws **E**, lock washers **Q**, and nuts **L**.

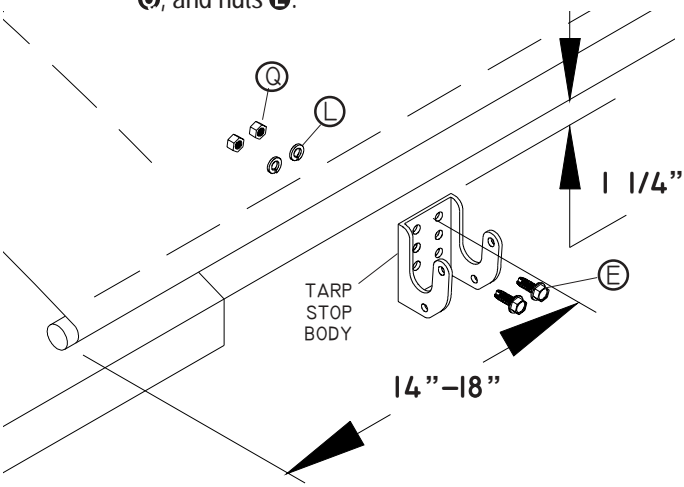

STEP 4: Equally space remaining tarp stop bodies. Mark and drill holes and fasten to box with screws **E**, lock washers **Q**, and nuts **L**.

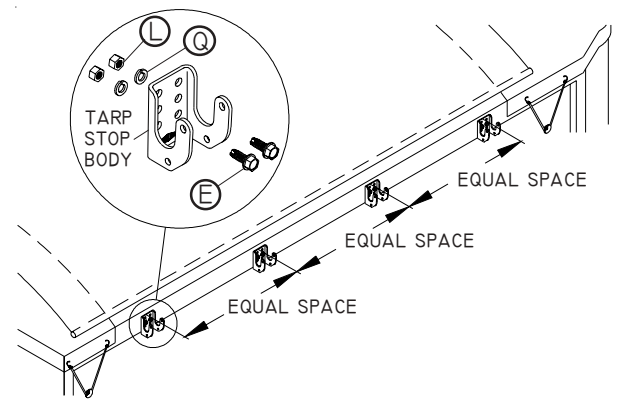

STEP 5: Adjust tarp, so fixed tube rests squarely in tarp stop bodies.

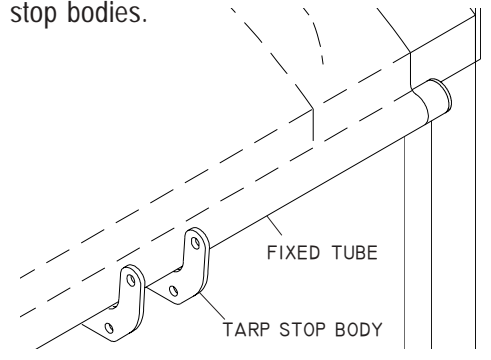

STEP 6: Fasten tarp stop uprights to tarp stop bodies with clevis pins. Secure with kickout rings.

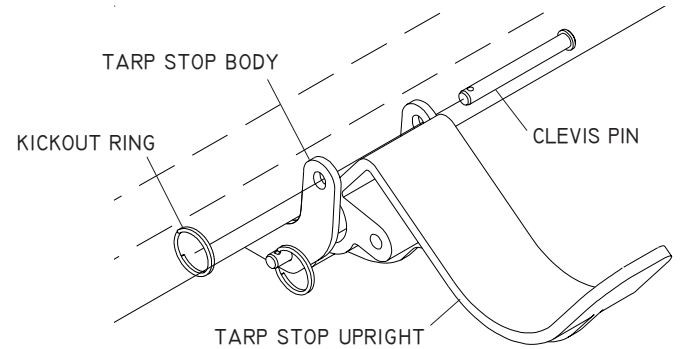

PBR STRAP/CABLE INSTALLATION



CAUTION

Close tarp and secure ratchets before driving vehicle to prevent tarp from blowing off.

Item	Part #	Description
1.	1100470	Ratchet Strap w/D-Ring, 5'-0"
2.	1106774	Ratchet Strap w/D-Ring, 9'-0"
3.	1107222	Hook Release Strap w/D-Ring, 5'-0"
4.	1107223	Hook Release Strap w/D-Ring, 7'-0"
5.	1106763	Roll Tube Web w/Cable, 7'-0"
6.	1106754	Ratchet Web w/Hook, 20'-0"
7.	1100457	Heavy Duty Ratchet, 2" for Web
8.	1701354	Plastic U-Clamp
B.	1700398	Self-Drilling Screw, 1/4" x 3/4"
E.	1700400	Self-Tapping Screw, 3/8" x 1"
L.	1700407	Hex Nut, 3/8"
Q.	1700434	Lock Washer, 3/8"

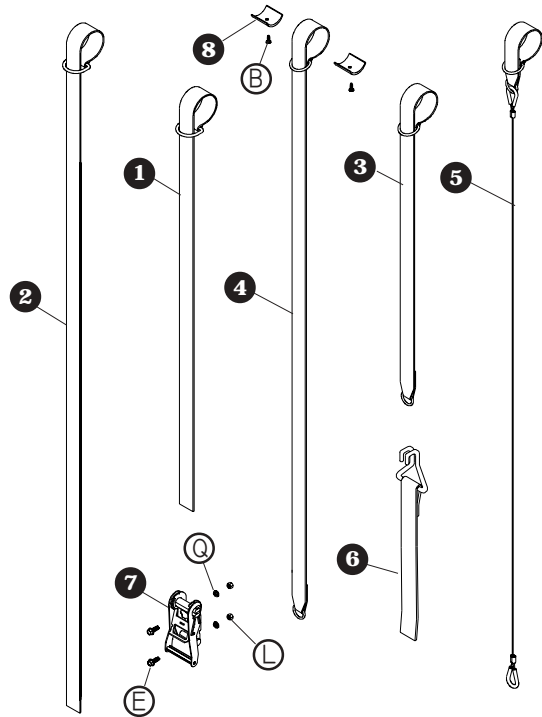

STEP 1: Locate first ratchet 14"-18" from rear edge of tarp at convenient operating height. Locate second ratchet 14"-18" from front edge of tarp at same height. Equally space remaining ratchets.

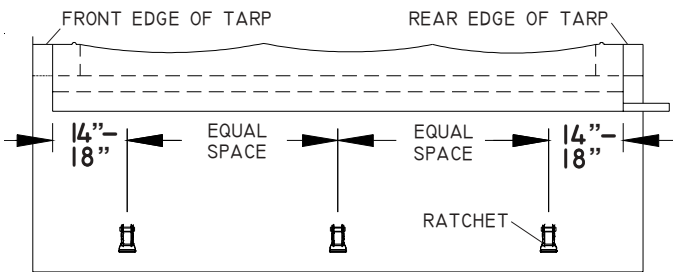

NOTE: Align ratchets with tarp stops on opposite side of box.

STEP 2: Mark and drill 5/16" holes, fasten with screws **E**, washers **Q**, and nuts **L**.

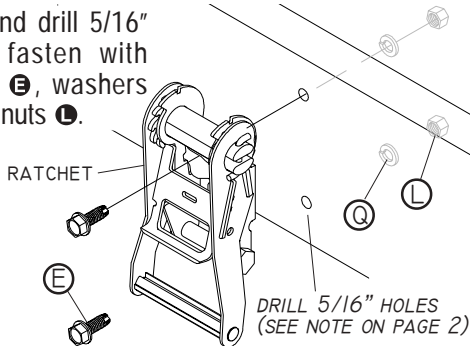

STEP 3: Cut 1" x 3" slots along bottom of 5" roll tube tarp pocket, directly above ratchets. Round corners of slots with scissors.

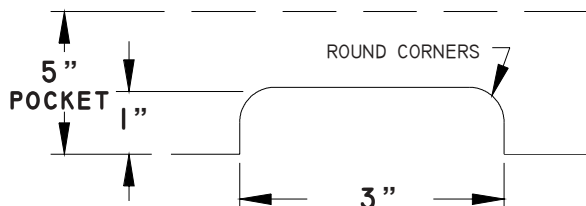

STEP 4: Extend roll tube 2-4" past farthest obstruction on rear of box. Cut front of roll tube to extend 1" past front of tarp. Grind cut edge smooth.

STEP 5: Thread straps or cables through slots, around roll tube and through D-Ring.

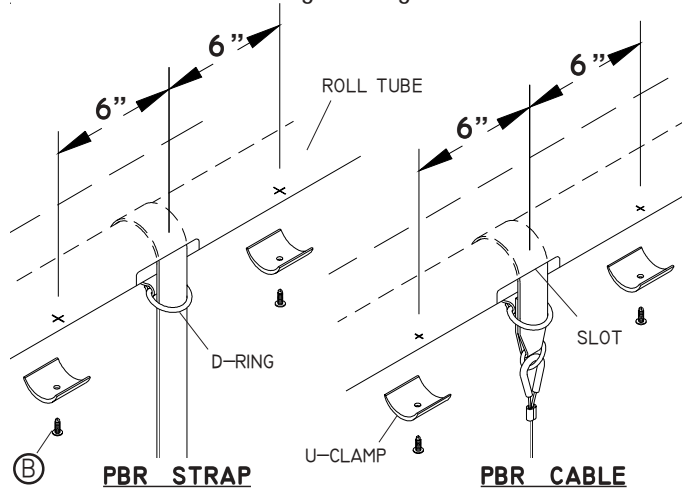

STEP 6: Mark U-Clamp locations on both sides of cables or straps, 6" from center. Install U-Clamps with self-drilling screws **B**.

STEP 7: Hook straps to ratchets as shown. Tighten straps securely before driving vehicle.

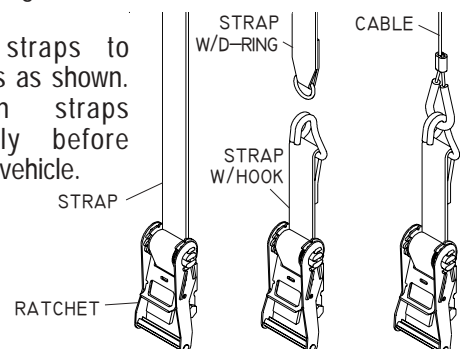

CRANK ARM ASSEMBLY

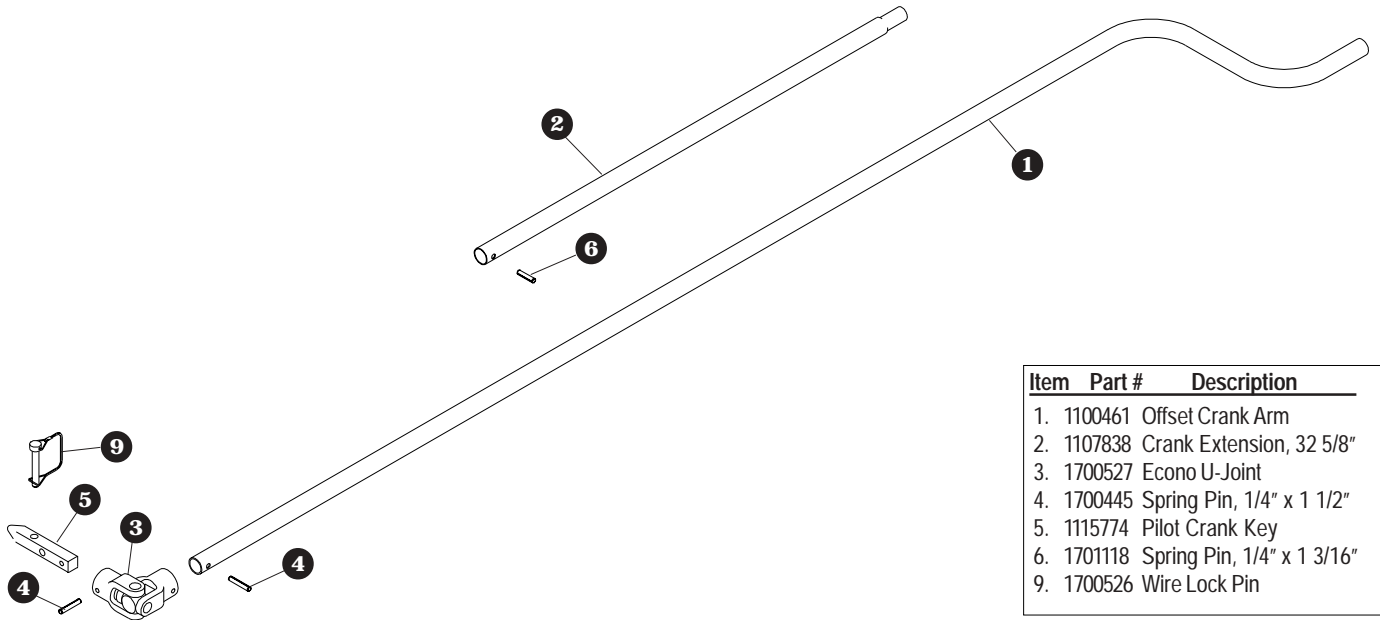

Item	Part #	Description
1.	1100461	Offset Crank Arm
2.	1107838	Crank Extension, 32 5/8"
3.	1700527	Econo U-Joint
4.	1700445	Spring Pin, 1/4" x 1 1/2"
5.	1115774	Pilot Crank Key
6.	1701118	Spring Pin, 1/4" x 1 3/16"
9.	1700526	Wire Lock Pin

STEP 1: (Optional) Insert crank extension into crank arm. Fasten with 1/4" x 1 3/16" spring pin.

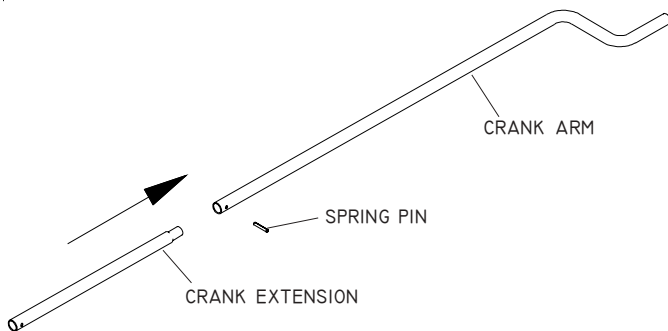

STEP 2: Insert crank arm/extension into U-Joint. Secure with 1/4" x 1 1/2" spring pin.

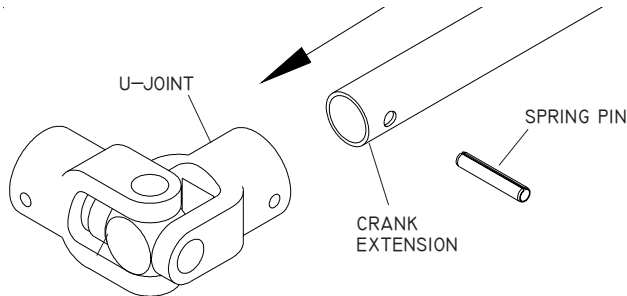

STEP 3: Insert crank key into U-Joint. Secure with 1/4" x 1 1/2" spring pin.

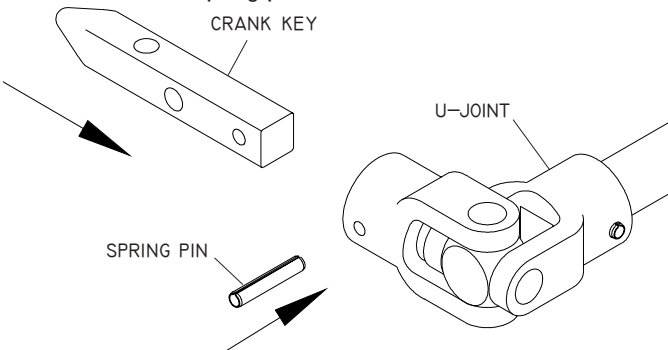

CRANK OPERATION OPTIONS:

Removeable crank operation - Open tarp with removeable crank arm, remove crank arm and close tarp with a rope. Store crank arm on box.
Fixed crank operation - Open and close tarp with fixed crank arm. Hook crank arm into crank retainer on rear of box.

REMOVEABLE CRANK OPERATION

STEP 4a: To roll tarp open, insert crank key into square key on roll tube at rear of box. Remove crank arm after opening tarp.

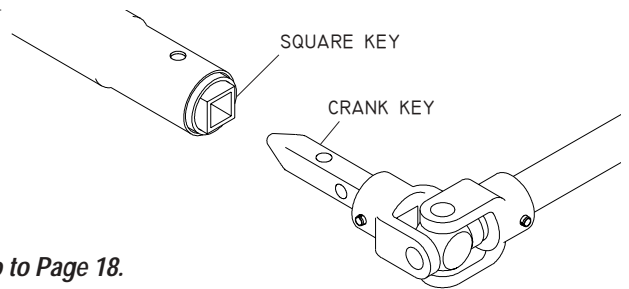

Go to Page 18.

FIXED CRANK OPERATION

STEP 4b: Insert crank key into square key on roll tube at rear of box. Align holes and fasten with wire lock pin.

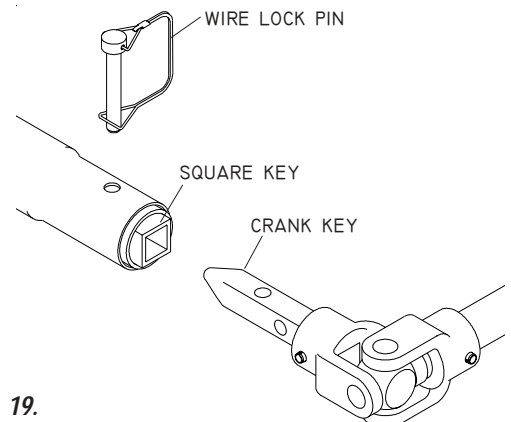

Go to Page 19.

REMOVABLE CRANK OPTION

Item	Part #	Description
1.	1101930	Offset J-Hook Crank Retainer
2.	1700526	Wire Lock Pin
3.	1100574	Cable w/#5 Interlock Snap
4.	1700682	Box Hook
5.	1100469	Rope, 1/4" x 32'-0"
C.	1700381	Cap Screw, 1/4" x 1"
E.	1700400	Self-Tapping Screw, 3/8" x 1"
G.	1700408	Hex Nut, 1/4"
L.	1700407	Hex Nut, 3/8"
P.	1700436	Lock Washer, 1/4"
Q.	1700434	Lock Washer, 3/8"

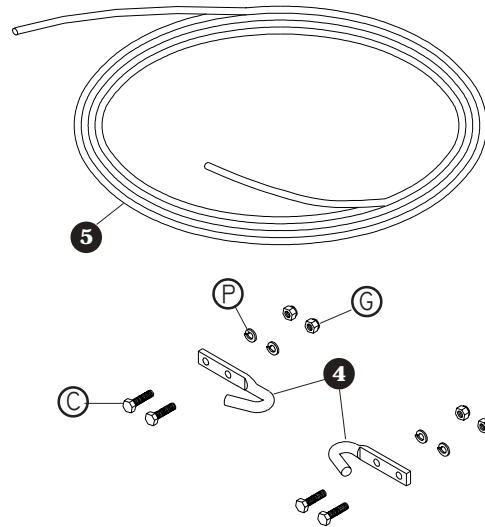
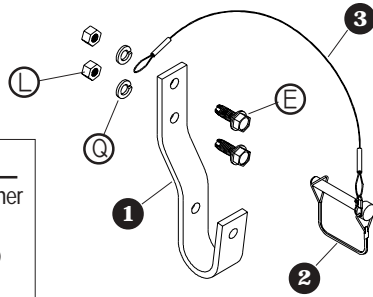

STEP 1: Locate and align crank retainers in a convenient location to store crank arm.

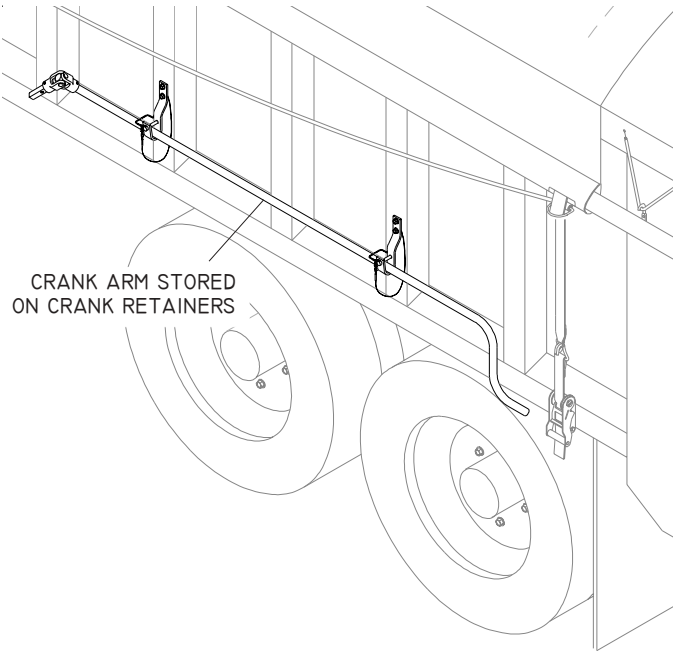

STEP 2: Mark and drill holes and fasten crank retainers to side of box with screws **E**, lock washers **Q**, and nuts **L**. Fasten cable between crank retainer and box.

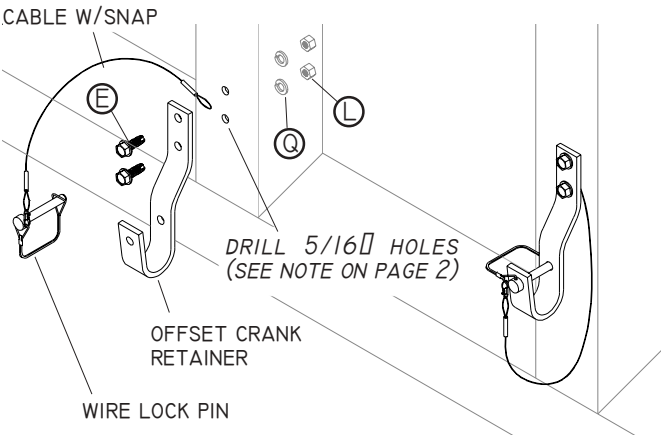

STEP 3: Melt hole in tarp at center of box. Tie loop in end of rope return. Thread loop through hole and pull loose end of rope through loop.

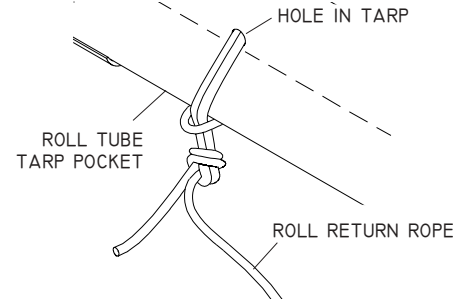

STEP 4: Locate box hooks where they will not interfere with ratchet operation. Mark and drill 3/16" holes and fasten with screws **C**, washers **P**, and nuts **G**.

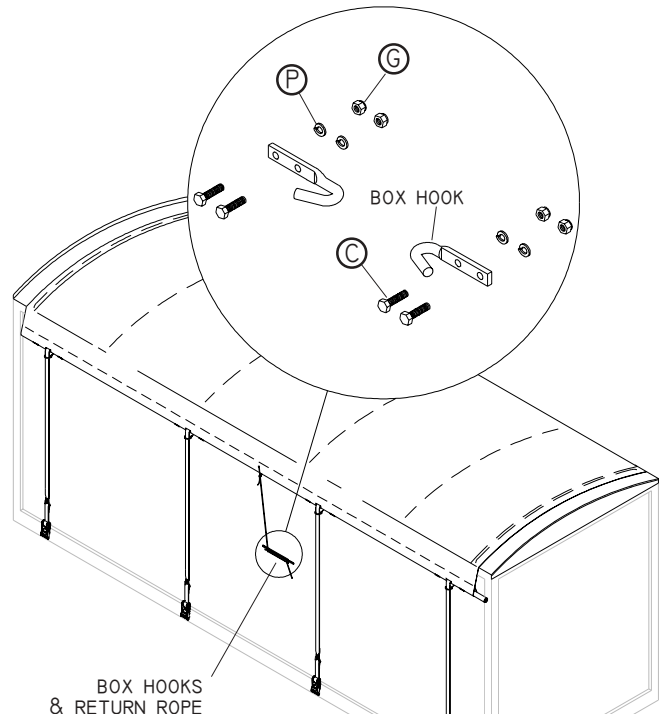

STEP 5: Wrap return rope around box hooks for storage while tarp is closed.

FIXED CRANK OPTION

Item	Part #	Description
1.	1101930	Offset J-Hook Crank Retainer
2.	1700526	Wire Lock Pin
3.	1100574	Cable w/#5 Interlock Snap
4.	1109478	Crank Retainer Stand-Off, 11"
	1100033	Crank Retainer Stand-Off, 7"
	1107080	Crank Retainer Stand-Off, 3"
	1100137	Crank Retainer Stand-Off, 2"
5.	1100306	Anchor Bushing
6.	1100040	J-Hook Crank Retainer
E.	1700400	Self-Tapping Screw, 3/8" x 1"
F.	1702996	Cap Screw, 1/2" x 1 1/4"
L.	1700407	Hex Nut, 3/8"
Q.	1700434	Lock Washer, 3/8"

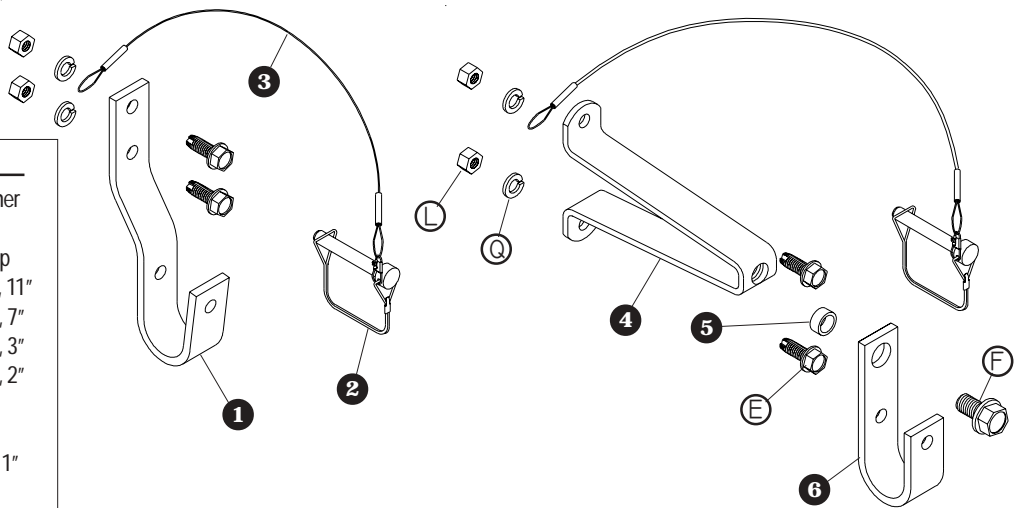

STEP 1: If using J-Hook crank retainer, assemble as shown.

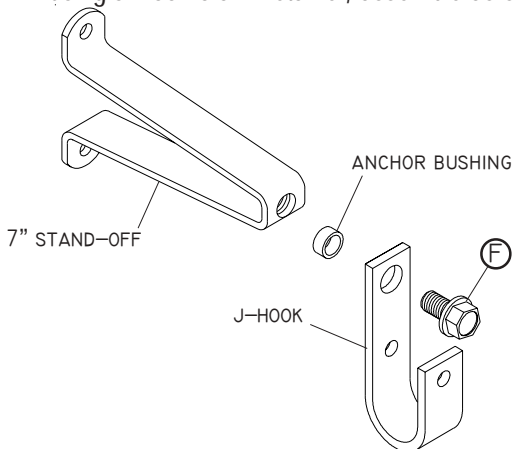

STEP 2: With tarp closed, rotate crank arm across rear of box to determine crank retainer position. Position crank retainer to hold crank arm securely in place.

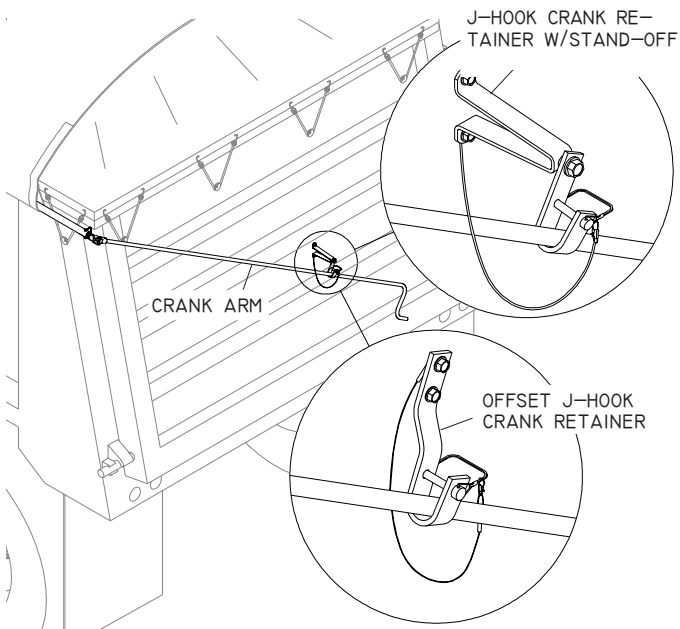

STEP 3: Mark and drill 5/16" holes and fasten crank retainer to box with screws (E), lock washers (Q), and nuts (L). Fasten cable w/snap and wire lock pin between stand-off and box.

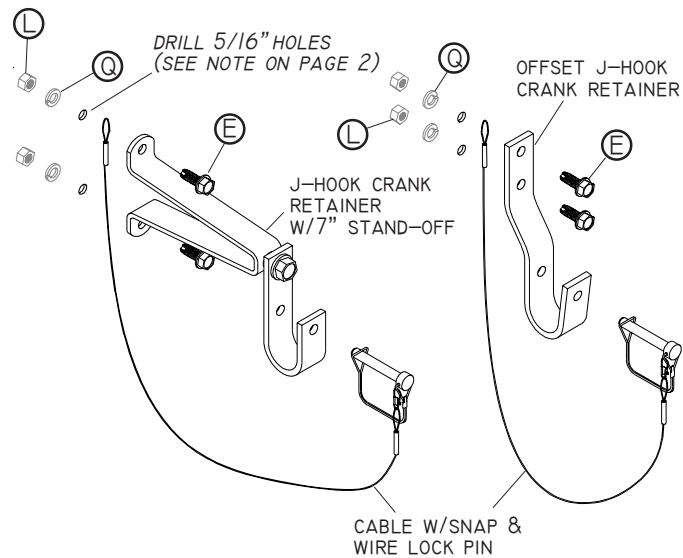

STEP 4: Hold crank firmly with both hands and roll tarp closed.

NOTE: Stretch cord return and gravity will force roll tube and crank arm downward when opening and closing tarp. Hold crank firmly with both hands while opening and closing tarp to prevent crank arm from spinning.

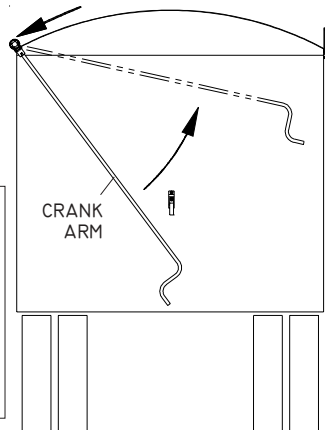

STRETCH CORD RETURN FOR FIXED CRANK OPTION

Item	Part #	Description
1.	1111067	Roll Return Tube Set
2.	1114360	Roll Return Cord, 11 1/2'
3.	1100138	Nylon End Plug
4.	1107680	Roll Return Cord Cover
A.		Self-Tapping Screw, #8 x 3/8"
H.		Hex Nut, 5/16"
J.		Nylon Lock Nut, 5/16"
S.		Flat Washer, 1/2"
M.		Eyebolt, 5/16" x 7/8" Thd

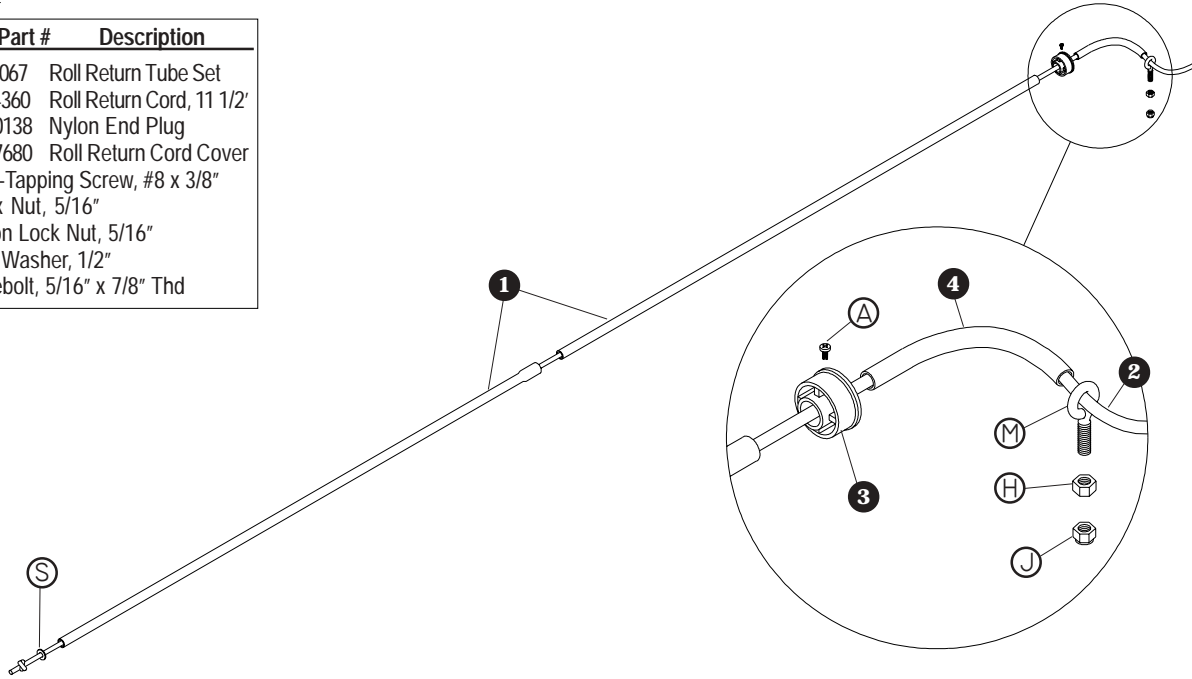

STEP 1: Insert straight pipe into belled pipe. Insert end plug into straight pipe.

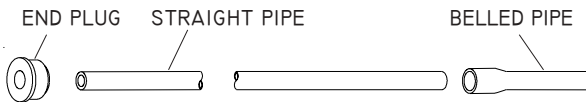

STEP 2: Insert stretch cord through end plug and pipes. Slide flat washer **S** over stretch cord and tie knot in cord.

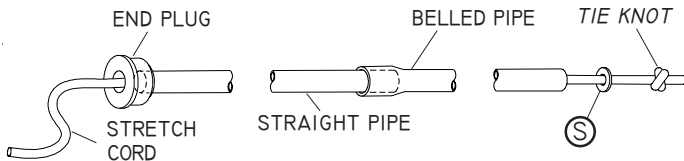

STEP 3: Insert stretch cord return into roll tube. Lightly tap end plug into roll tube.

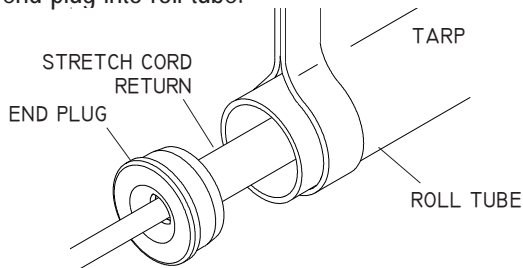

STEP 4: Drill 9/64" hole about 7/16" from edge of end plug. Secure with screw **A**.

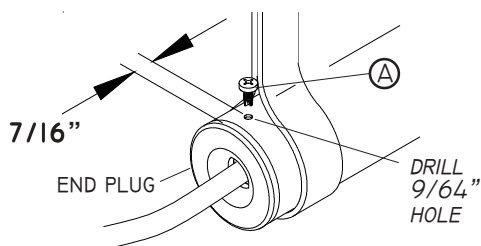

STEP 5: Drill 13/32" hole through box, 1 1/2" from edge of tarp, and 2 1/2" to 5 1/2" down from top edge of top rail. Insert eyebolt **M** through hole and secure with nut **H** and lock nut **J**.

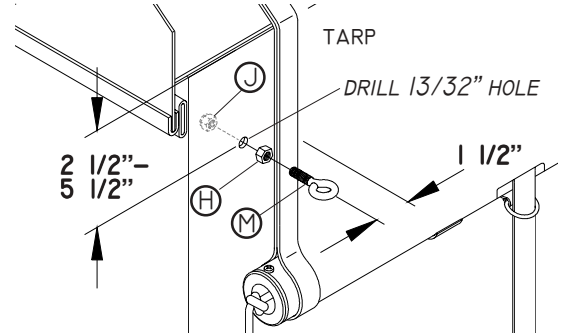

STEP 6: With tarp hanging over edge of box, pull stretch cord to remove all slack in stretch cord return. Slide protective cover over stretch cord.

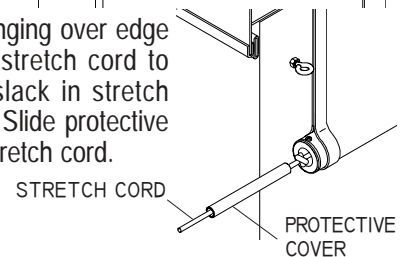

STEP 7: Thread stretch cord through eyebolt. Pull cord to create enough tension to almost lift roll return. Tie knot.

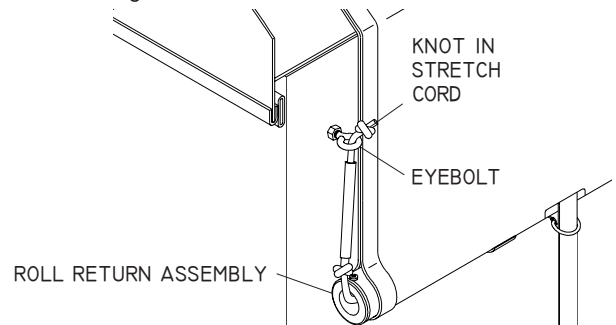

STEP 8: Cut off excess stretch cord, melt end to prevent fraying.

The Premium Belted Tarping System is designed to provide years of reliable service. Follow the installation instructions, maintenance schedule, and operating instructions provided to receive years of service from your PBR system. Incorrect operation, or lack of maintenance can severely impair operation of the system, and cause premature tarp and cable wear.

MAINTENANCE SCHEDULE

Every 2-4 weeks:

1. Inspect tarp - repair any tears, cuts, or worn areas.
2. Inspect hardware - securely tighten any loose fasteners.

OPERATING INSTRUCTIONS

Removeable Crank

To uncover load:

1. Release all hold-down straps from ratchets.
2. Unwrap rope return from storage hooks.
3. Remove crank from crank retainers, and insert square key into square end of roll tube.
4. Turn crank clockwise (counter-clockwise for reverse roll) until tarp has rolled up against tarp stops.
5. Detach crank from roll tube, and place crank back into crank retainers.

To cover load:

1. Pull rope return to roll tarp closed.
2. Store rope return by wrapping rope around storage hooks.
3. Connect hold-down straps to ratchets, and ratchet straps down until tarp is correctly tensioned.

Fixed Crank

To uncover load:

1. Release all hold-down straps from ratchets.
2. Release crank from crank retainer.
3. Turn crank clockwise (counter-clockwise for reverse roll) until tarp has rolled up against tarp stops.
4. Place crank back into crank retainer.

To cover load:

1. Release crank from crank retainer.
2. Turn crank counter-clockwise (clockwise for reverse roll) until tarp is hanging over edge of trailer, completely unrolled.
3. Place crank back into crank retainer.
4. Connect hold-down straps to ratchets and ratchet straps down until tarp is correctly tensioned

Close cover at all times except when loading or unloading, to extend the life of your PBR system.

Open cover while unloading box. Unloading box with cover closed will create a vacuum which could cause system damage.

PBR REPLACEMENT PARTS - EXPLODED VIEW

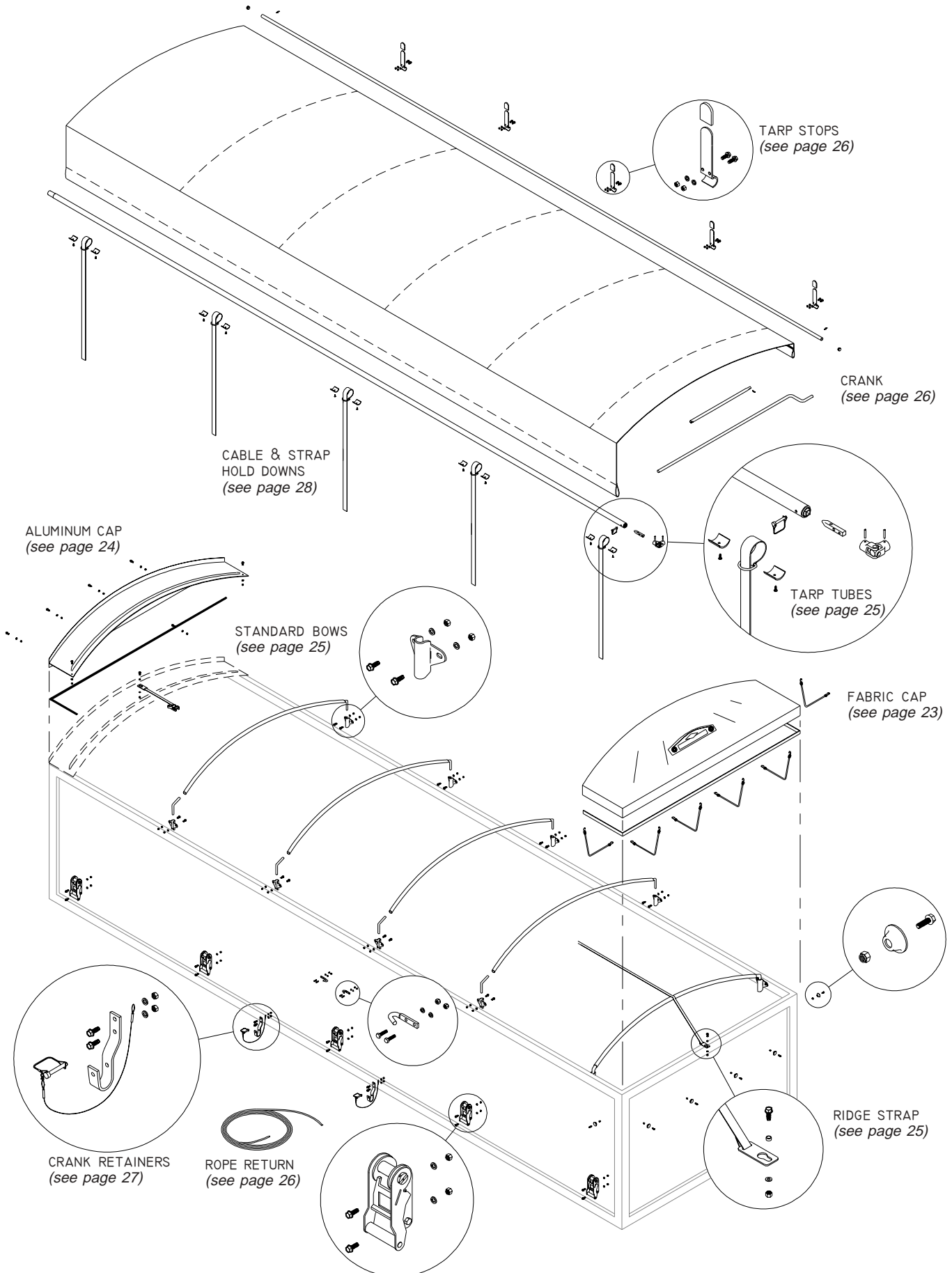

PBR REPLACEMENT PARTS

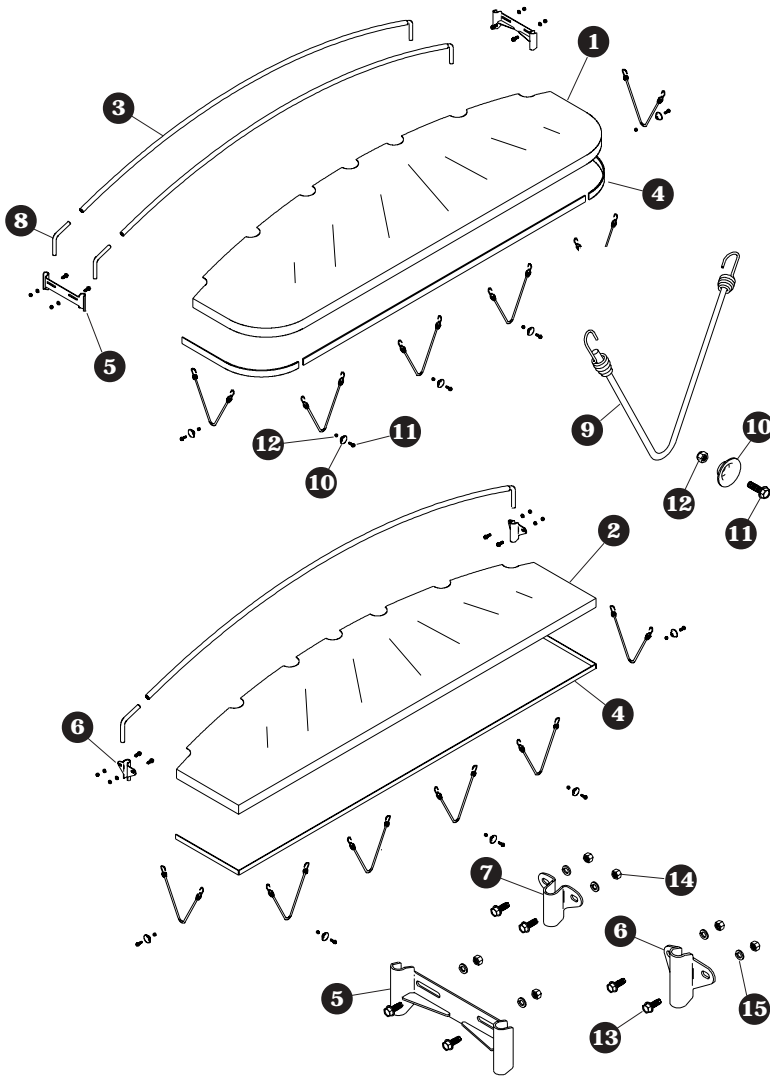

FABRIC CAPS

Item	Part No.	Part Name
1100642		Fabric Cap Bow Kit, Double Front Low Rise <i>(includes items 3-5, & 8-15)</i>
1100641		Fabric Cap Bow Kit, Double Front High Rise <i>(includes items 3-5, & 8-15)</i>
1100640		Fabric Cap Bow Kit, Single Back Low Rise <i>(includes items 3, 4, 6, 8, & 9-15)</i>
1100639		Fabric Cap Bow Kit, Single Back High Rise <i>(includes items 3, 4, 6, 8, & 9-15)</i>
1113359		Fabric Cap Bow Kit, Single Back Low Rise Universal Bracket <i>(includes items 3, 4, & 7-15)</i>
1113360		Fabric Cap Bow Kit, Single Back High Rise Universal Bracket <i>(includes items 3, 4, & 7-15)</i>
1	—	<u>Front Cap Fabric Only</u> Square Front, 96" Square Front, 102" Radius/Diagonal Front, 96" Radius/Diagonal Front, 102"
2	—	<u>Rear Cap Fabric Only</u> Square Back, 96" Square Back, 102"
3	1100760	Low Rise Bow
	1100762	High Rise Bow
4	1700581	Flat Bar, 103"
5	1108211	Double Bow Bracket
6	1107009	Single Bow Bracket
7	1115702	Universal Bow Bracket
8	1100695	Low Rise Bow Shank
	1106925	High Rise Bow Shank
9	1700990	Shock Cord
10	1701355	Rope Anchor
11	1701059	Self-Tapping Screw, 5/16" x 1"
12	1700419	Nylon Lock Nut, 5/16"
13	1700400	Self-Tapping Screw, 3/8" x 1"
14	1700407	Hex Nut, 3/8"
15	1700434	Lock Washer, 3/8"

EASY-OFF END CAPS

Item	Part No.	Part Name
1.	*	Easy-Off Front Cap
2.	*	Easy-Off Back Cap
3.	1701115	Rubber Seal
4.	1701113	Over-Center Clamp w/Safety Clip
5.	1701218	D-Ring, 1 1/2"
6.	1701114	D-Ring Bracket
7.	1701059	Self-Tapping Screw, 5/16" x 1"
8.	1700419	Nylon Lock Nut, 5/16"

* Specify Size

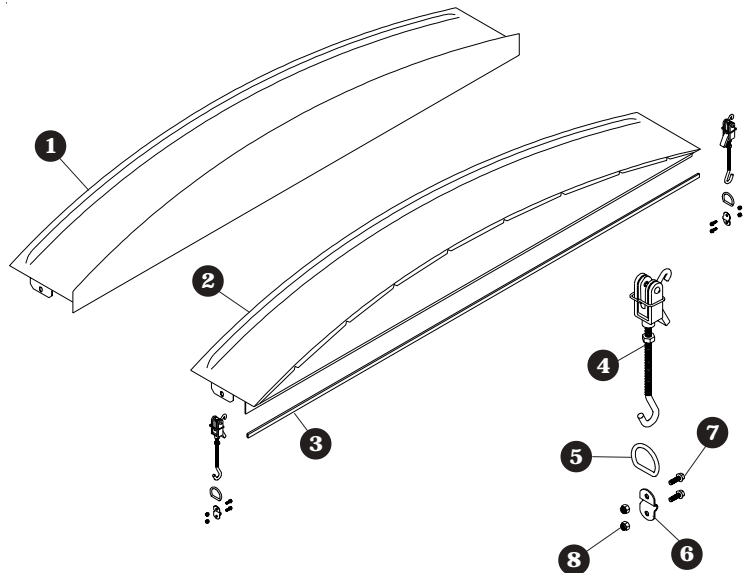

PBR REPLACEMENT PARTS

ALUMINUM END CAPS

Item	Part No.	Part Name
1		ALUMINUM FRONT CAPS
		Square Front - 94"
		Square Front - 96"
		Square Front - 102"
		Radius/Diagonal Front - 96"
		Radius/Diagonal Front - 102"
		Universal Front - 96"
		Universal Front - 102"
		Square Flat Front Cap
2		ALUMINUM BACK CAPS
		Square Back - 94"
		Square Back - 96"
		Square Back - 102"
		Flat Back Cap
3	1107785	Aluminum Cap Hardware w/Trim Seal 110"
	1100786	Aluminum Cap Hardware w/Trim Seal 132"
	1100165	Trim Seal - 110"
	1100357	Trim Seal - 132"
	1700152	Trim Seal (Per Foot)
4.	1700400	Self-Tapping Screw, 3/8" x 1"
5.	1700434	Lock Washer, 3/8"
6.	1700407	Hex nut, 3/8"

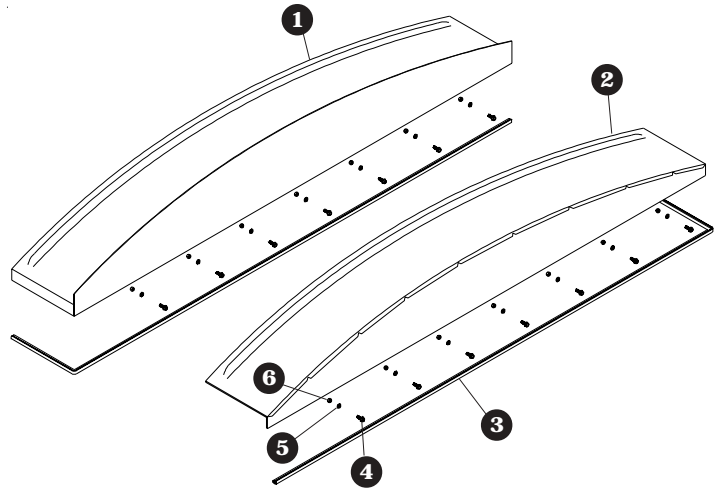

GALVANIZED STEEL END CAPS

Item	Part No.	Part Name
1.	1108977	Galvanized Low Rise Cap - 93"
	1108980	Galvanized Low Rise Cap - 95"
	1108983	Galvanized Low Rise Cap - 100"
2.	1108986	Galvanized High Rise Cap - 93"
	1108989	Galvanized High Rise Cap - 95"
	1108992	Galvanized High Rise Cap - 100"
3	1700400	Self-Tapping Screw, 3/8" x 1"
4	1700434	Lock Washer, 3/8"
5	1700407	Hex Nut, 3/8"

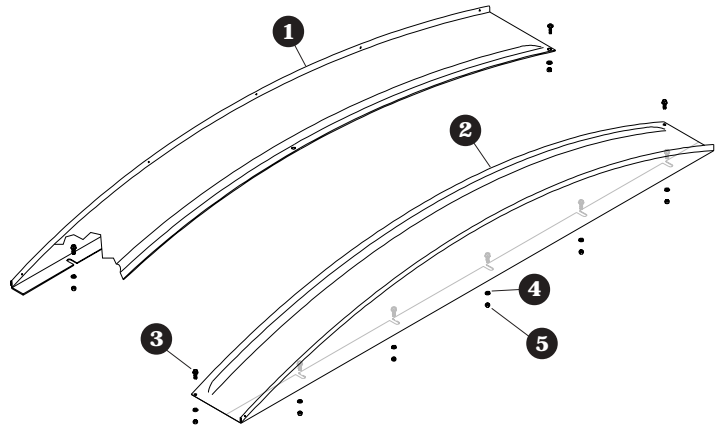

VALUE SERIES BOWS

Item	Part No.	Part Name
	1108552	Value Series Low Rise Bow Kit <i>(includes items 1-6)</i>
	1108558	Value Series High Rise Bow Kit <i>(includes items 1-6)</i>
1.	1108548	Value Series Low Rise Bow
	1108549	Value Series High Rise Bow
2.	1108550	Value Series Bow Shank
3.	1700398	Self-Drilling Screw, 1/4" x 3/4"
4.	1700407	Hex Nut, 3/8"
5.	1700434	Lock Washer, 3/8"
6.	1700400	Self-Tapping Screw, 3/8" x 1"

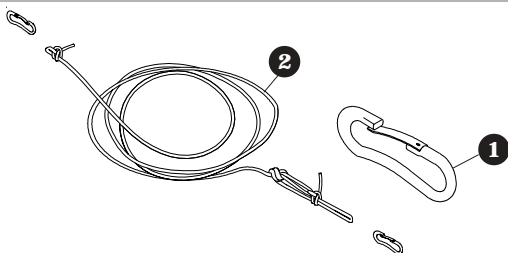
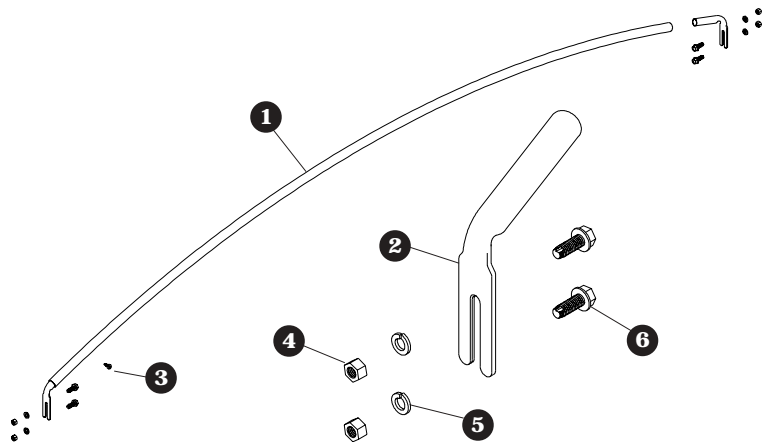

RIDGE ROPE

Item	Part No.	Part Name
	1108573	Ridge Rope Kit w/Snaps 30'
	1108957	Ridge Rope Kit w/Snaps 50'
1.	1700666	Steel Wire Snap
2.	1108574	Rope, 1/4" x 30'
	1108958	Rope, 1/4" x 50'

PBR REPLACEMENT PARTS

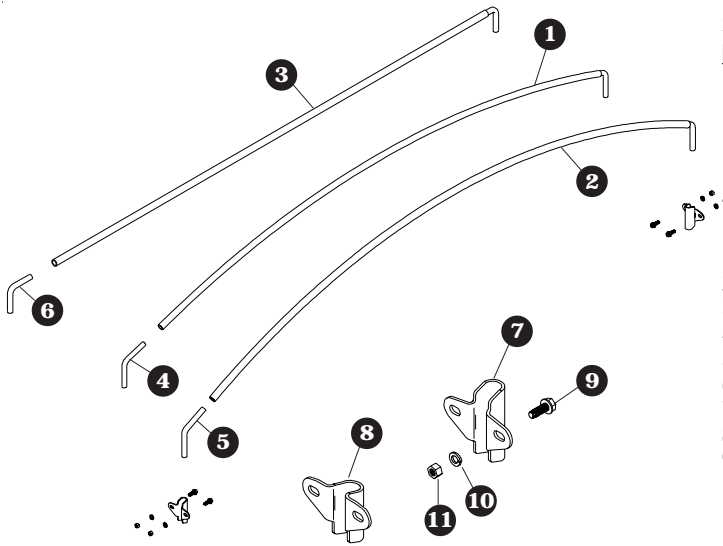

STANDARD STEEL BOWS

Item	Part No.	Part Name
	1111781	Standard Flat Bow Kit (includes items 3, 6, 7, & 9 - 11)
	1100766	Standard Low Rise Bow Kit (includes items 1, 4, & 9 - 11)
	1100768	Standard High Rise Bow Kit (includes items 2, 5, & 9 - 11)
	1109139	Standard Low Rise Bow Kit, Universal Bracket (includes items 1, 4, & 8 - 11)
	1109091	Standard High Rise Bow Kit, Universal Bracket (includes items 2, 5, & 8 - 11)
1	1100760	Standard Low Rise Bow
2	1100762	Standard High Rise Bow
3	1109149	Standard Flat Bow
4	1100695	Standard Low Rise Bow Shank
5	1106925	Standard High Rise Bow Shank
6	1109150	Standard Flat Bow Shank
7	1107009	Single Bow Bracket
8	1115702	Single Bow Bracket, Universal
9	1700400	Self-Tapping Screw, 3/8" x 1"
10	1700434	Lock Washer, 3/8"
11	1700407	Hex Nut, 3/8"

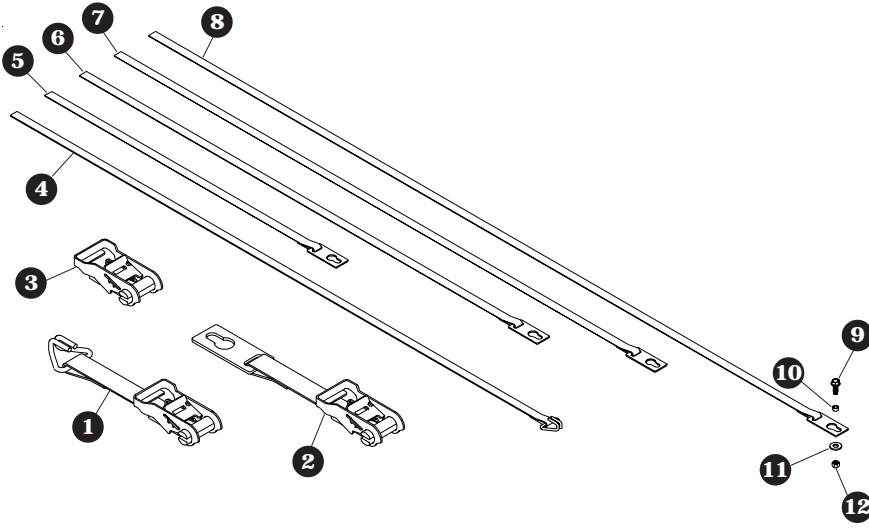

1" RIDGE STRAPS

Item	Part No.	Part Name
	1101685	Ridge Strap Kit w/Anchor 1" x 25' (includes items 2, 5, & 9 - 12)
	1101686	Ridge Strap Kit w/Anchor 1" x 39' (includes items 2, 6, & 9 - 12)
	1101687	Ridge Strap Kit w/Anchor 1" x 46' (includes items 2, 7, & 9 - 12)
	1107068	Ridge Strap Kit w/Anchor 1" x 56' (includes items 2, & 8 - 12)
	1101833	Ridge Strap Kit w/Hook 1" x 46' (includes items 1 & 4)
1	1106153	Ratchet w/1" Ridge Strap & Hook
2	1101678	Ratchet w/1" Ridge Strap & Anchor
3	1700836	Ratchet for 1" Web
4	1101835	Ridge Strap w/Hook, 1" x 46'
5	1101680	Ridge Strap w/Anchor, 1" x 25'
6	1101681	Ridge Strap w/Anchor, 1" x 39'
7	1101682	Ridge Strap w/Anchor, 1" x 46'
8	1107066	Ridge Strap w/Anchor, 1" x 56'
9	1700400	Self-Tapping Screw, 3/8" x 1"
10	1101683	Anchor Bushing
11	1701176	Flat Washer, 3/8"
12	1700418	Centerlock Hex Nut, 3/8"

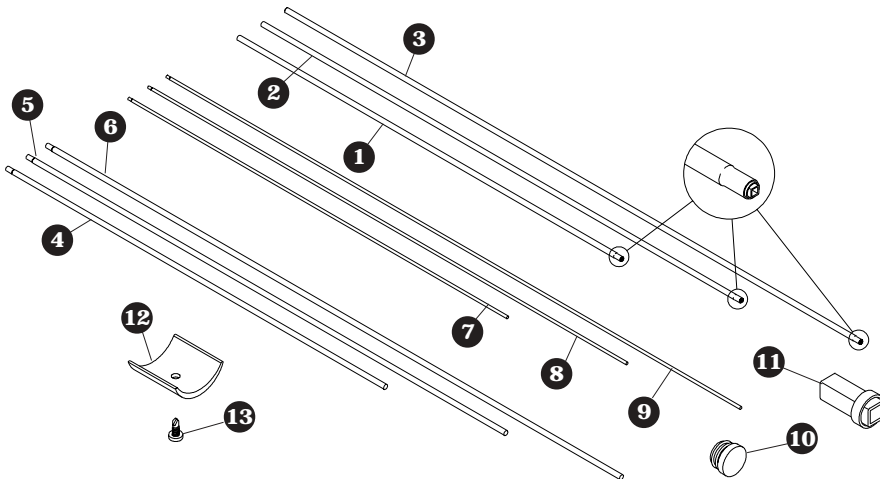

TARP TUBES

Item	Part No.	Part Name
1	1105132	Roll Tube w/Socket, 2" x 16'
2	1105131	Roll Tube w/Socket, 2" x 20'
3	1105124	Roll Tube w/Socket, 2" x 24'
4	1700048	Roll Tube, 2" x 16'-3"
5	1700046	Roll Tube, 2" x 20'-3"
6	1701427	Roll Tube, 2" x 24'-3"
7	1700051	Fixed Tube, 1 1/8" x 16'-3"
8	1700049	Fixed Tube, 1 1/8" x 20'-3"
9	1701428	Fixed Tube, 1 1/8" x 24'-3"
10	1700523	Plastic End Plug
11	1105033	Roll Tube Key
12	1701354	Plastic U-Clamp
13	1700398	Self-Drilling Screw, 1/4" x 3/4"

PBR REPLACEMENT PARTS

TARP STOPS

Item	Part No.	Part Name
	1111092	Standard Tarp Stop Kit <i>(includes items 1, 2, & 5 - 7)</i>
	1111093	Offset Tarp Stop Kit <i>(includes items 1, 3, & 5 - 7)</i>
	1111096	Recessed Tarp Stop Kit <i>(includes items 1, & 4 - 7)</i>
	1111094	Easy-Off Aluminum Tarp Stop Kit <i>(includes items 5 - 8, 12, 13, & 15)</i>
	1111095	Easy-Off Aluminum 6" Offset Tarp Stop Kit <i>(includes items 5 - 8, & 12 - 14)</i>
	1114047	Easy-Off Flexible Tarp Stop Kit <i>(includes items 5 - 8, 10, 12 - 13)</i>
	1114388	Easy-Off Flexible 6" Offset Tarp Stop Kit <i>(includes items 5 - 9, 12 - 13)</i>
	1101407	Easy-Off Aluminum Tarp Stop Assy <i>(includes items 8, 12, 13, & 15)</i>
	1105169	Easy-Off Aluminum 6" Offset Tarp Stop Assy <i>(includes items 8, & 12 - 14)</i>
	1114017	Easy-Off Flexible Tarp Stop Assy <i>(includes items 8, 10, & 12, 13)</i>
	1114515	Easy-Off Flexible 6" Offset Tarp Stop Assy <i>(includes items 8, 9, & 12, 13)</i>
1	1700729	Protective Cap
2	1100049	Standard Tarp Stop
3	1100392	Offset Tarp Stop
4	1105163	Recessed Tarp Stop
5	1700400	Self-Tapping Screw, 3/8" x 1"
6	1700434	Lock Washer, 3/8"
7	1700407	Hex Nut, 3/8"
8	1700799	Kickout Ring, 1"
9	1115217	Easy-Off Flexible 6" Offset Tarp Stop w/Safety Plate
10	1115216	Easy-Off Flexible Tarp Stop w/Safety Plate
11	1114630	Easy-Off Flexible Tarp Stop Safety Plate
12	1100833	Easy-Off Tarp Stop Body
13	1700044	Clevis Pin, 5/16" x 2 7/8"
14	1105168	Easy-Off Aluminum 6" Offset Tarp Stop Upright
15	1100834	Easy-Off Aluminum Tarp Stop Upright

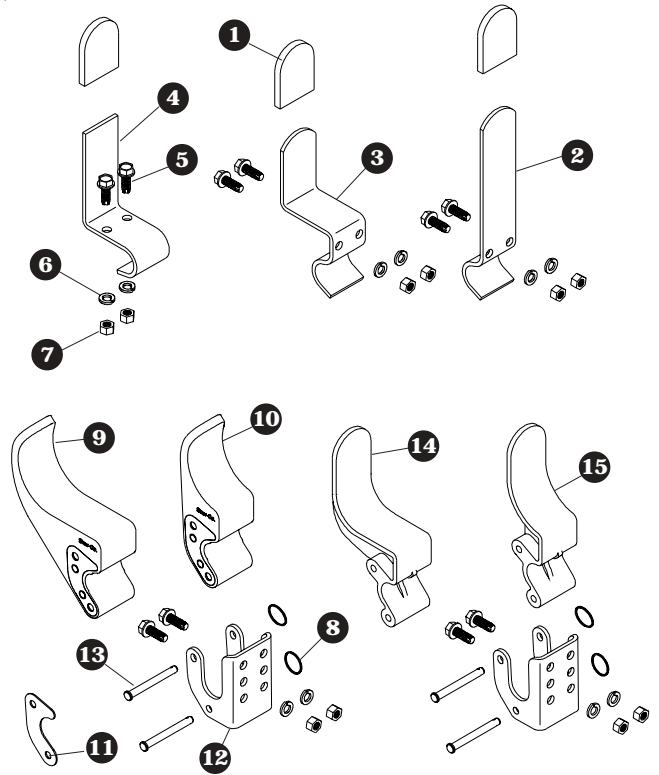

CRANKS

Item	Part No.	Part Name
	1100061	Standard Crank Arm Kit <i>(includes items 1 - 4, & 6)</i>
	1101500	Long Crank Arm Kit <i>(includes items 1 - 6)</i>
1.	1115774	Pilot Crank Key
2.	1700527	Econo U-Joint
3.	1700445	Spring Pin, 1/4" x 1 1/2"
4.	1100461	Offset Crank Arm
5.	1107838	Square Crank Extension, 33"
6.	1701118	Spring Pin, 1/4" x 1 3/16"
7.	1700526	Wire Lock Pin

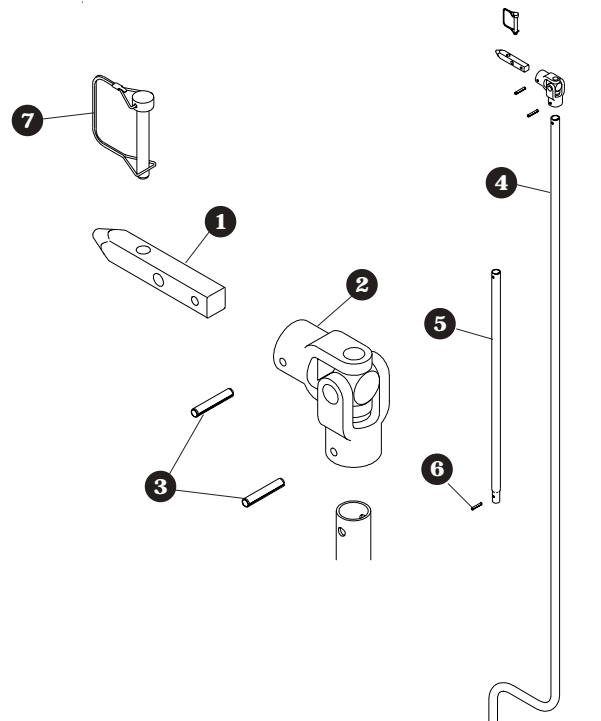

ROPE RETURN

Item	Part No.	Part Name
	1100064	Rope Return Kit <i>(includes items 1 - 5)</i>
1.	1100469	Rope, 32'
2.	1700381	Cap Screw, 1/4" x 1"
3.	1700408	Hex Nut, 1/4"
4.	1700436	Lock Washer, 1/4"
5.	1700682	Box Hook

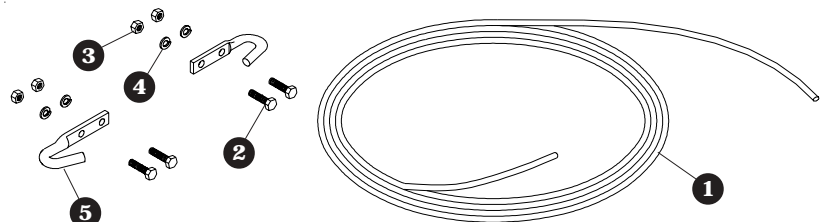

PBR REPLACEMENT PARTS

CRANK RETAINERS

Item	Part No.	Part Name
	1100386	Crank Retainer Kit w/7" Standoff (includes items 1 - 5, 14, 15, & 18)
	1100388	Crank Retainer Kit w/2" Standoff (includes items 1 - 5, 14, 15, & 16)
	1107047	Pinless Crank Retainer Kit w/7" Standoff (includes items 1, 2, 4, 13, 14, 15, & 18)
	1107048	Pinless Crank Retainer Kit w/2" Standoff (includes items 1, 2, 4, 13, & 14 - 16)
	1107052	Pinless Crank Retainer Hardware (includes items 13, 14, & 15)
	1101929	Offset Crank Retainer Kit (includes items 1 - 6)
	1114603	Offset Pinless Crank Retainer Kit (includes items 1, 2, 4, & 6 - 12)
	1114602	Offset Pinless Crank Retainer Kit, Retrofit (includes items 7 - 12)
1	1700407	Hex Nut, 3/8"
2	1700434	Lock Washer, 3/8"
3	1100574	Cable w/#5 Interlock Snap
4	1700400	Self-Tapping Screw, 3/8" x 1"
5	1700526	Wire Lock Pin
6	1101930	Offset J-Hook, Crank Retainer
7	1114599	Crank Retainer Base Plate
8	1703134	Tension Spring
9	1114600	Crank Retainer Lock
10	1703133	Clevis Pin, 5/16" x 1 3/4"
11	1700448	Cotter Pin, 3/32"
12	1700427	Flat Washer, 1/4"
13	1100306	Retainer Bushing, 11/16"
14	1100040	J-Hook Crank Retainer
15	1702996	Cap Screw, 1/2" x 1 1/4"
16	1100137	Crank Retainer Standoff, 2"
17	1107080	Crank Retainer Standoff, 3"
18	1100033	Crank Retainer Standoff, 7"
19	1109478	Crank Retainer Standoff, 11"
20	1115511	Stainless Steel Crank Retainer Standoff w/Nut, 7"
21	1115513	Stainless Steel Crank Retainer Standoff w/Nut, 11"

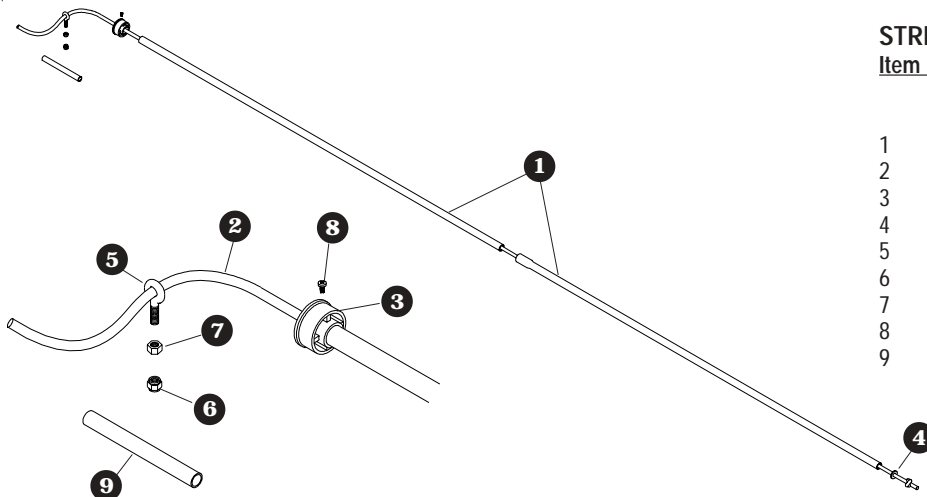
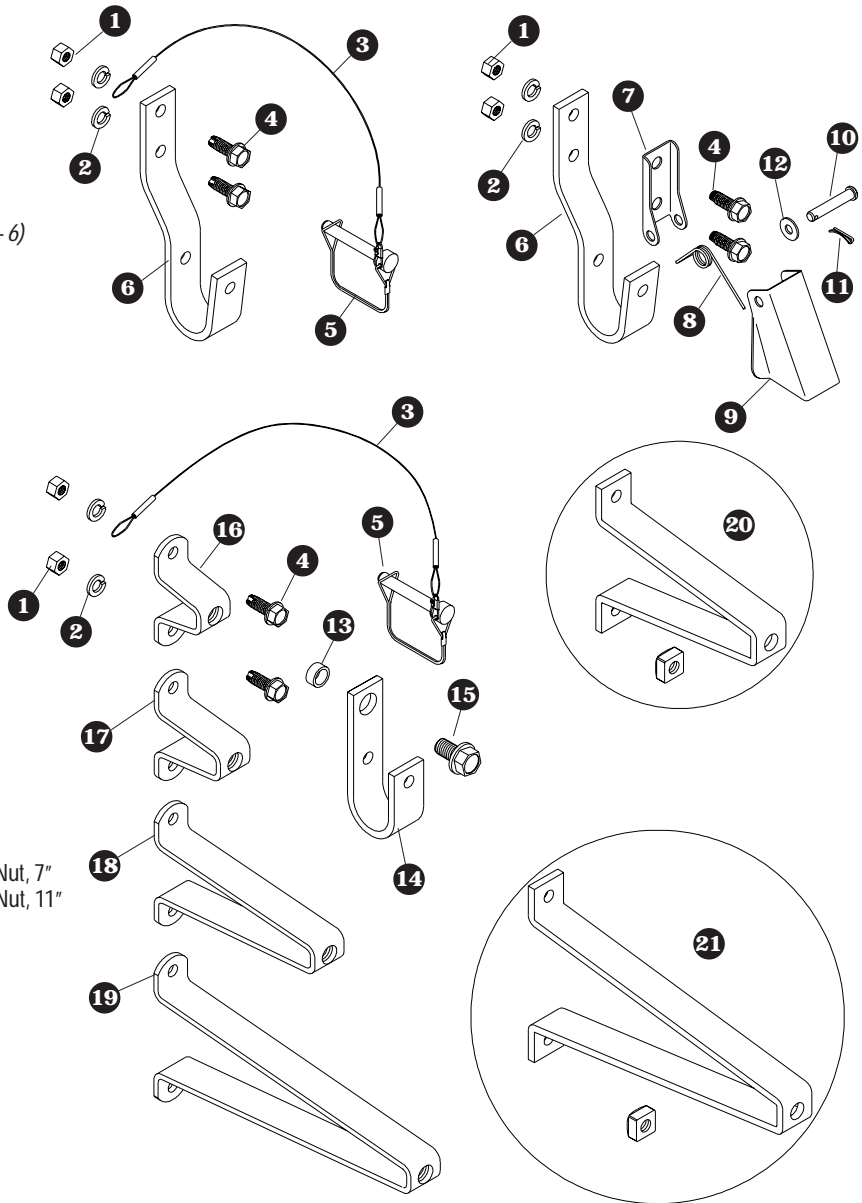

STRETCH CORD RETURN

Item	Part No.	Part Name
	1114359	Replacement Roll Return Kit (includes items 1 - 9)
1	1111067	Roll Return Tube Set
2	1114360	Replacement Stretch Cord Kit
3	1100138	Nylon End Plug
4	1703373	Flat Washer, 1/2"
5	1700717	Eyebolt, 5/16"
6	1700419	Nylon Lock Nut, 5/16"
7	1700411	Hex nut, 5/16"
8	1700084	Self-Tapping Screw, #8 x 3/8"
9	1107680	Roll return Cord Cover

PBR REPLACEMENT PARTS

CABLE & STRAP HOLD DOWNS

Item	Part No.	Part Name
	1106770	Cable Hold-Down Assembly - 7'-0"
	1106771	Ratchet Strap Assembly - 5'-0"
	1106772	Ratchet Strap Assembly - 9'-0"
	1107224	Hook Release Strap Assembly - 5'-0"
	1107225	Hook Release Strap Assembly - 7'-0"
1	1106774	Ratchet Strap D-Ring Assembly - 9'-0"
2	1100470	Ratchet Strap D-Ring Assembly - 5'-0"
3	1701354	Plastic U-Clamp
4	1700398	Self-Drilling Screw, 1/4" x 3/4"
5	1107223	Hook Release Strap/D-Ring Assembly - 7'-0"
6	1107222	Hook Release Strap/D-Ring Assembly - 5'-0"
7	1106763	Roll Tube Web/Cable Assembly - 7'-0"
8	1100457	Ratchet, 2"
9	1700400	Self-Tapping Screw, 3/8" x 1"
10	1700434	Lock Washer, 3/8"
11	1700407	Hex Nut, 3/8"
12	1106754	Ratchet Web/Hook Assembly

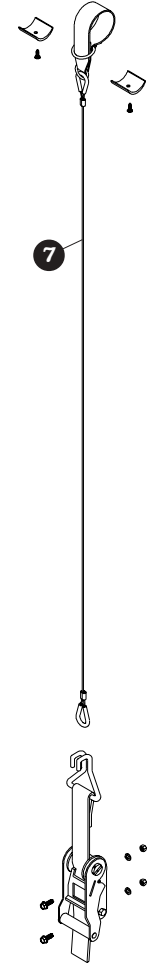
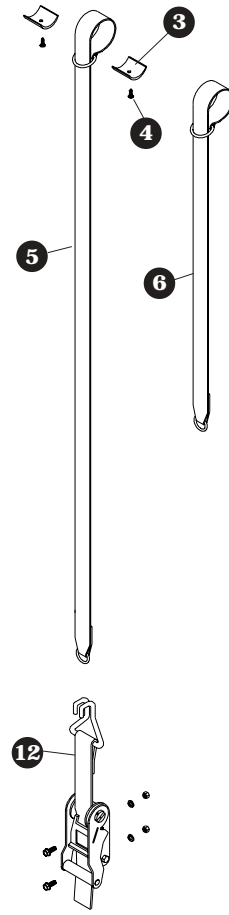
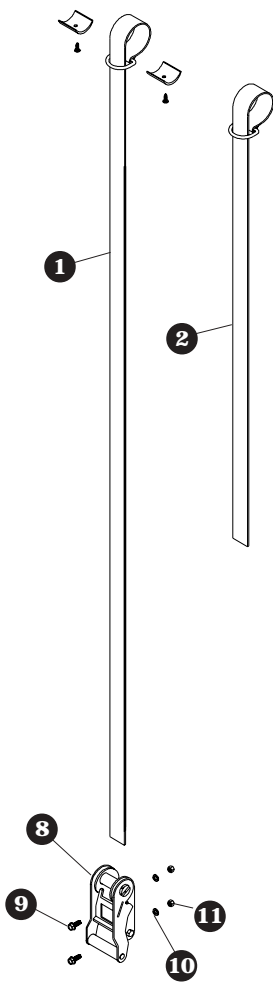

BOW COVERS

Vinyl coated compound that wraps over your bows and clips underneath with u-clips. Reduces tarp wear and grain splatter, prevents rust, and provides traction. Extra wide bow covers also available.

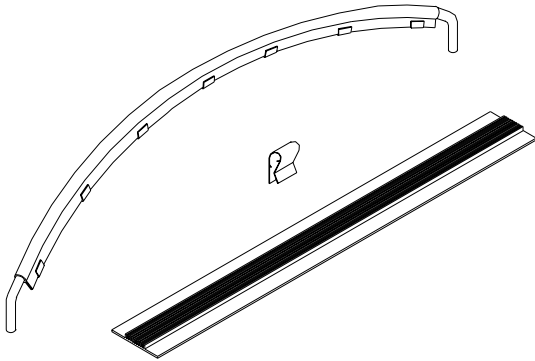

OFFSET PINLESS CRANK RETAINER - 1114603

Secure the crank arm more quickly and safely than ever before! No pins and cables to hassle with. Easy to install using the same bolt pattern as the offset J-hook crank retainer. Works with the Shur-Flex crank. Retrofit kits available.

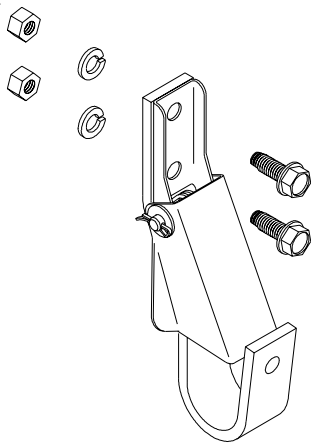

FRONT CABLE RETURN - 1111122

Uses a non-stretch cable and a heavy duty internal tension spring and pulley system. It is exactly what cold climates demand.

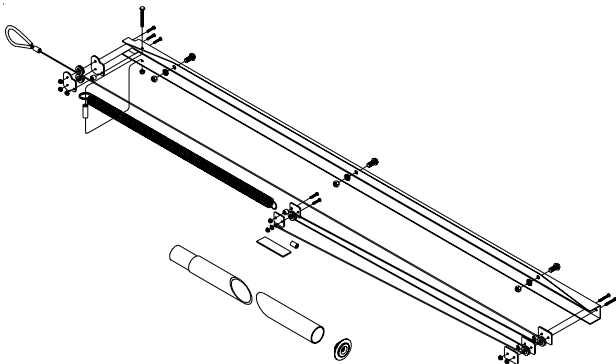

STAINLESS STEEL

Ask about our stainless steel components.

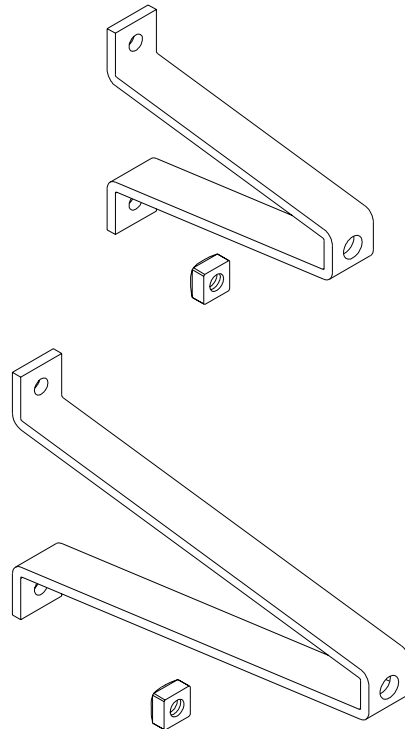

SHUR-PRO TARP REPAIR KIT

Shur-Co.'s deluxe tarp repair kit, the Shur-Pro, repairs your tarp professionally using the heat seal method. No messy adhesives or solvents. This kit includes a Wagner heat gun, scissors, a roller, 12 feet of 18 oz. or 22 oz. repair tarp in any specified color and instructions.



STANDARD TARP REPAIR KIT

Shur-Co.'s standard tarp repair kit comes complete with adhesive, cleaner, 10 sq. feet of tarp in any specified color and instructions.



TARP OPTIONS

- 22 oz. - Heavy Duty Fabric
- Multi-Color Tarps
- Personalized Tarps
- Reinforcements
- Extra Length or Width
- 13 Vibrant Colors Available



"Your Tarp Solutions Company!"

QUALITY SHUR-CO. PRODUCTS...

- Shur-Lok® Roll Up Tarp
- Super Duty Shur-Lok®
- Heavy Duty Shur-Lok®
- Shur-Lok® Junior
- Super Duty Electric Shur-Lok®
- Value Series Electric Shur-Lok®
- Value Series Shur-Lok®
- Value Series Belt & Ratchet
- Shur-Matic II® Arm System
- Shur-Trak II™ Cable System
- Cover-Pro II® Cable System
- Premium Belt & Ratchet
- Cover-Up™ Pull System
- Lightweight Hay Covers
- Combine Hopper Extension Covers
- Fitted & Flat Covers
- Turning Point Bow System
- Flexbow® System
- Aluminum Bow System
- Heavy Duty Bow System
- Flatbed Load Control
- Interior Van Cargo Control
- Lumber, Wallboard, Steel, Smoke & Coil Tarps
- Genuine Replacement Parts & Tarps



**End Dumps, Belly Dumps,
Dump Bodies, Farm Boxes,
Grain Trailers, & Open Top Vans**

Questions about your Shur-Lok?

**CALL
TOLL FREE**

1-888-4 SHUR-CO
(1-888-474-8726)